

ENGINEER TO VERIFY BELOW POINTS:-
 1) WELD PLATES LOCATIONS.
 2) TIMBERS FINISHING.
 3) BOTTOM PROFILE OF PANEL.
 4) PANEL HEIGHT CONFIRM.
 5) SP3 & SP4 SIZE CONFIRM.

LEGEND :-
 [Symbol] PRECAST PANEL START
 TBC = TO BE CONFIRM

REV.	DATE	DESCRIPTION	DRAWN	APPROVED
G	27.07.22	REVISED AS PER COMMENTS	AS	
F	25.06.22	REVISED AS PER COMMENTS	AS	
E	18.06.22	REVISED AS PER COMMENTS	AS	
D	04.06.22	REVISED AS PER COMMENTS	AS	
C	10.05.22	REVISED AS PER COMMENTS	AS	

LEVEL 1 FLOOR PRECAST PANEL LAYOUT FOR BUILDING C

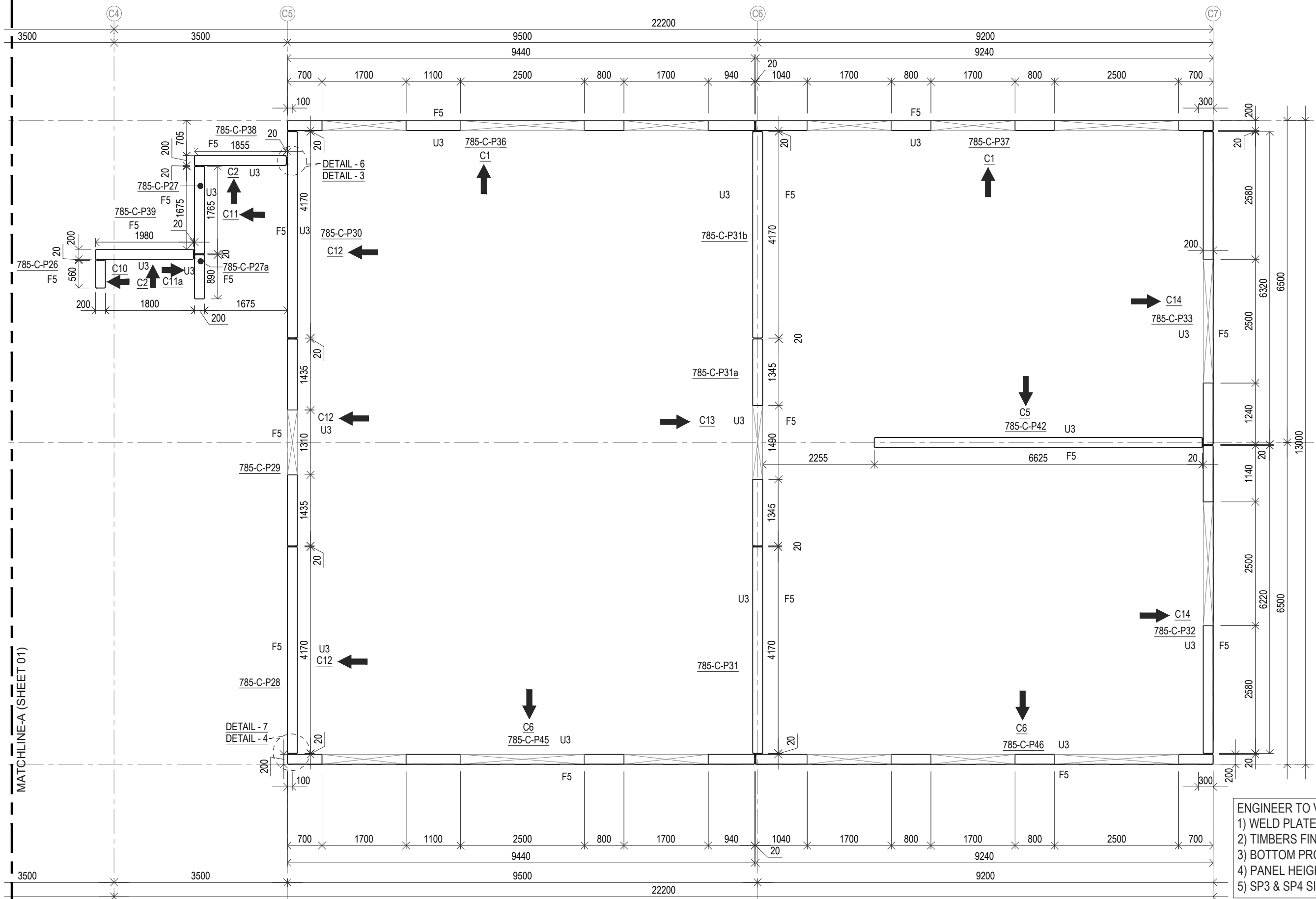

ENGINEER TO VERIFY BELOW POINTS:-
 1) WELD PLATES LOCATIONS.
 2) TIMBERS FINISHING.
 3) BOTTOM PROFILE OF PANEL.
 4) PANEL HEIGHT CONFIRM.
 5) SP3 & SP4 SIZE CONFIRM.

LEVEL 1 FLOOR PRECAST PANEL LAYOUT FOR BUILDING C

LEGEND :-
 [Symbol] PRECAST PANEL START
 TBC = TO BE CONFIRM

REV.	DATE	DESCRIPTION	DRAWN	APPROVED
G	27.07.22	REVISED AS PER COMMENTS	AS	
F	25.06.22	REVISED AS PER COMMENTS	AS	
E	18.06.22	REVISED AS PER COMMENTS	AS	
D	04.06.22	REVISED AS PER COMMENTS	AS	

Contractor		Job		Title		COPYRIGHT RESERVED	Drawn	AS	Date	2022	Job No. 785	
MCLEOD GREEN, 148-162 MCLEOD ROAD, TE ATATU SOUTH		LEVEL 1 PRECAST PANEL PLAN LAYOUT BUILDING C		Checked	HP		Scale (A3)	1:75	Dwg No. 8	G	REV.	

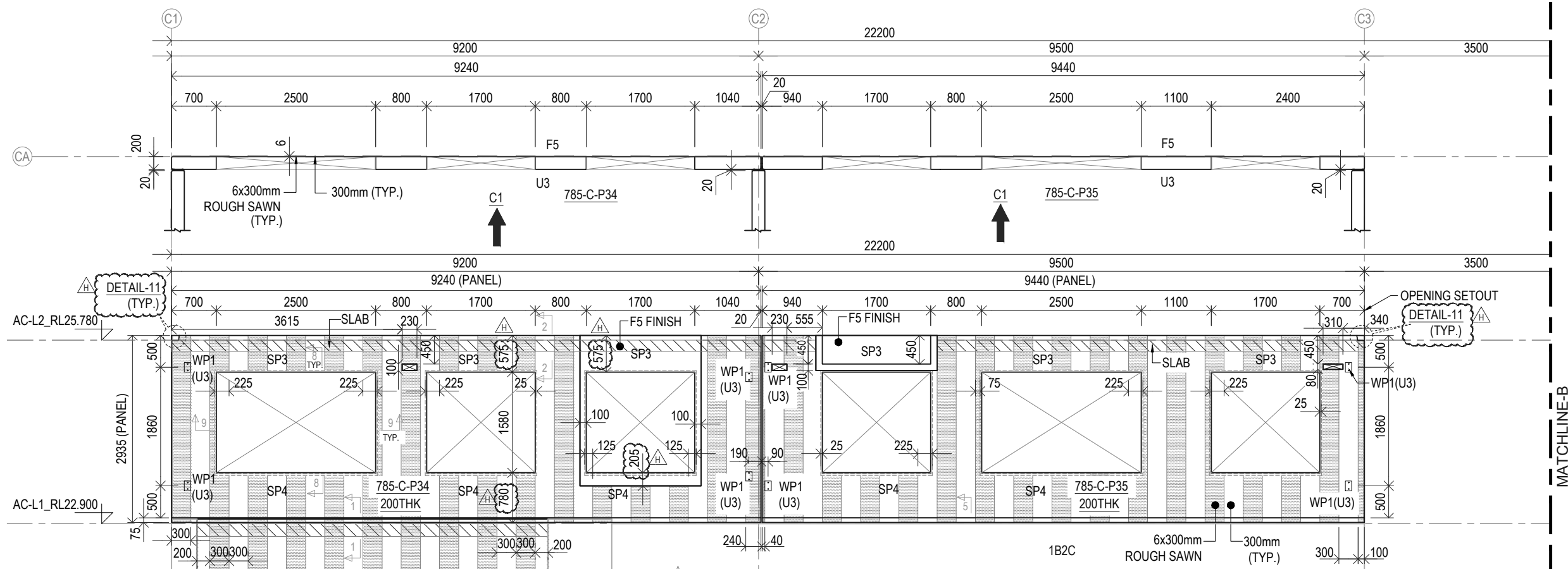

GRID CA PANEL ELEVATION (ELEVATION-C1)

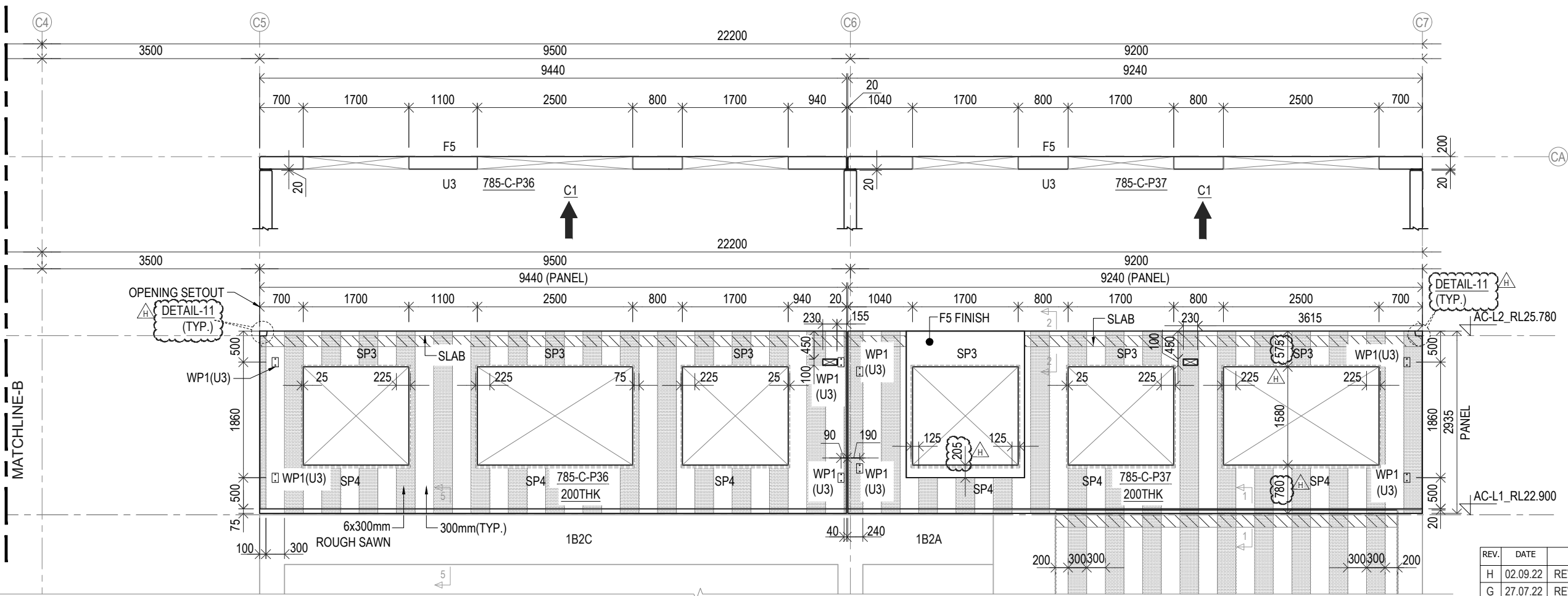

GRID CA PANEL ELEVATION (ELEVATION-C1)

ENGINEER TO VERIFY BELOW POINTS:-
 1) WELD PLATES LOCATIONS.
 2) TIMBERS FINISHING.
 3) BOTTOM PROFILE OF PANEL.
 4) PANEL HEIGHT CONFIRM.
 5) SP3 & SP4 SIZE CONFIRM.

LEGEND :-
 [Symbol] PRECAST PANEL START
 TBC = TO BE CONFIRM

REV.	DATE	DESCRIPTION	DRAWN	APPROVED
H	02.09.22	REVISED AS PER COMMENTS	JM	
G	27.07.22	REVISED AS PER COMMENTS	AS	
F	25.06.22	REVISED AS PER COMMENTS	AS	
E	18.06.22	REVISED AS PER COMMENTS	AS	

Contractor		Job		Title		COPYRIGHT RESERVED	Drawn	AS	Date	2022	Job No.	785
MCLEOD GREEN, 148-162 MCLEOD ROAD, TE ATATU SOUTH		LEVEL 1 PRECAST PANEL ELEVATIONS BUILDING C		Checked	HP							

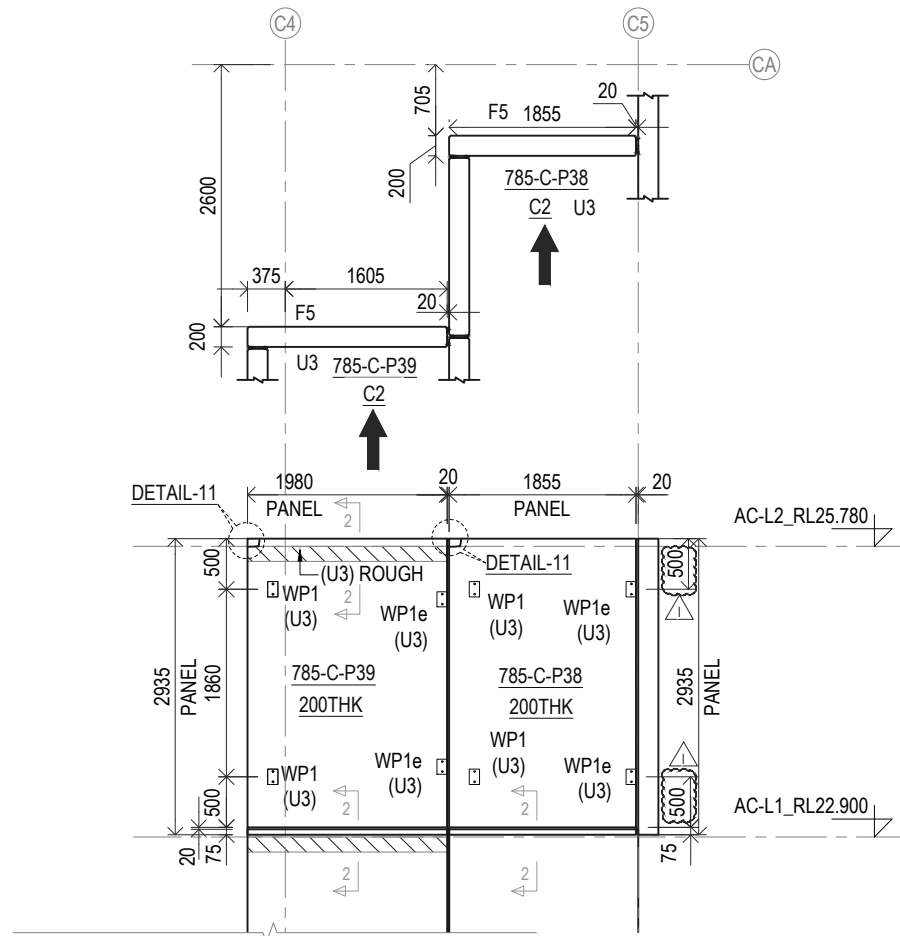

GRID CA+ PANEL ELEVATION (ELEVATION-C2)

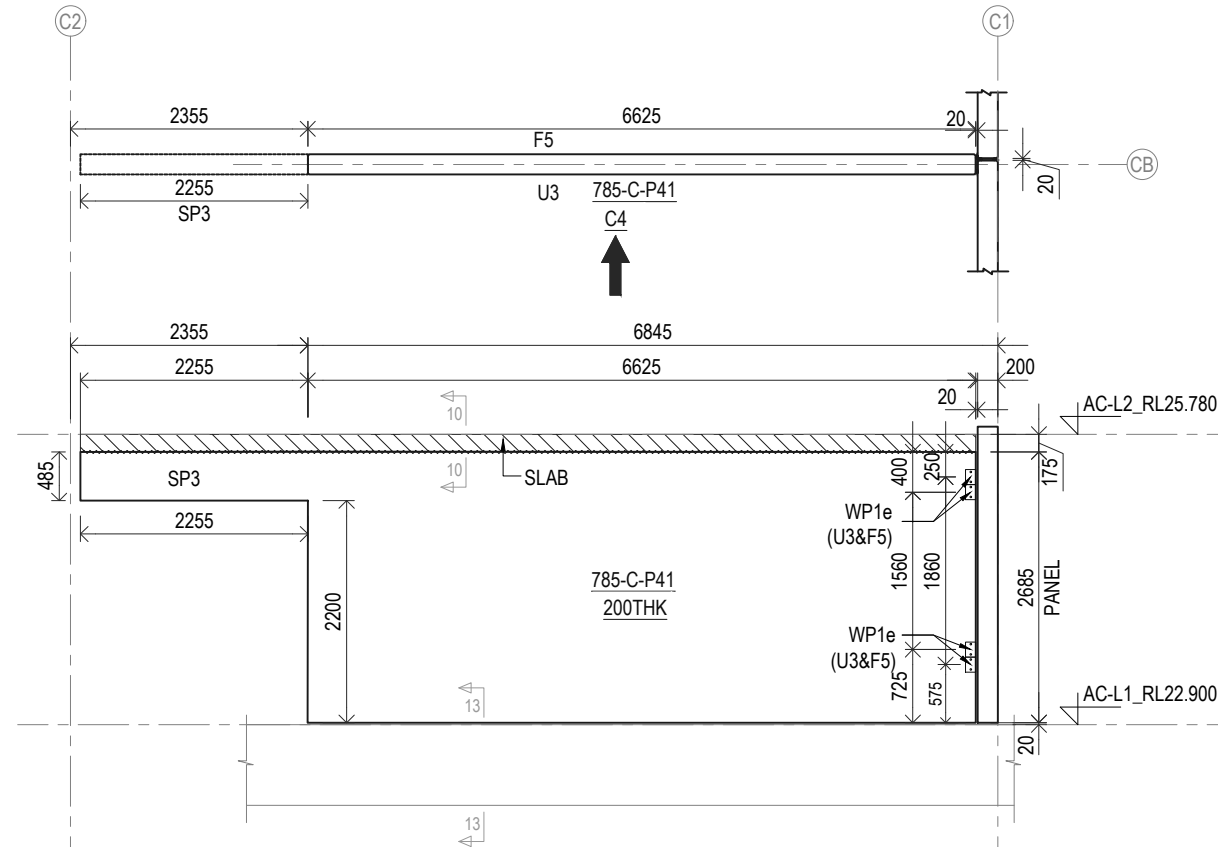

GRID CB/C1-C2 PANEL ELEVATION (ELEVATION-C4)

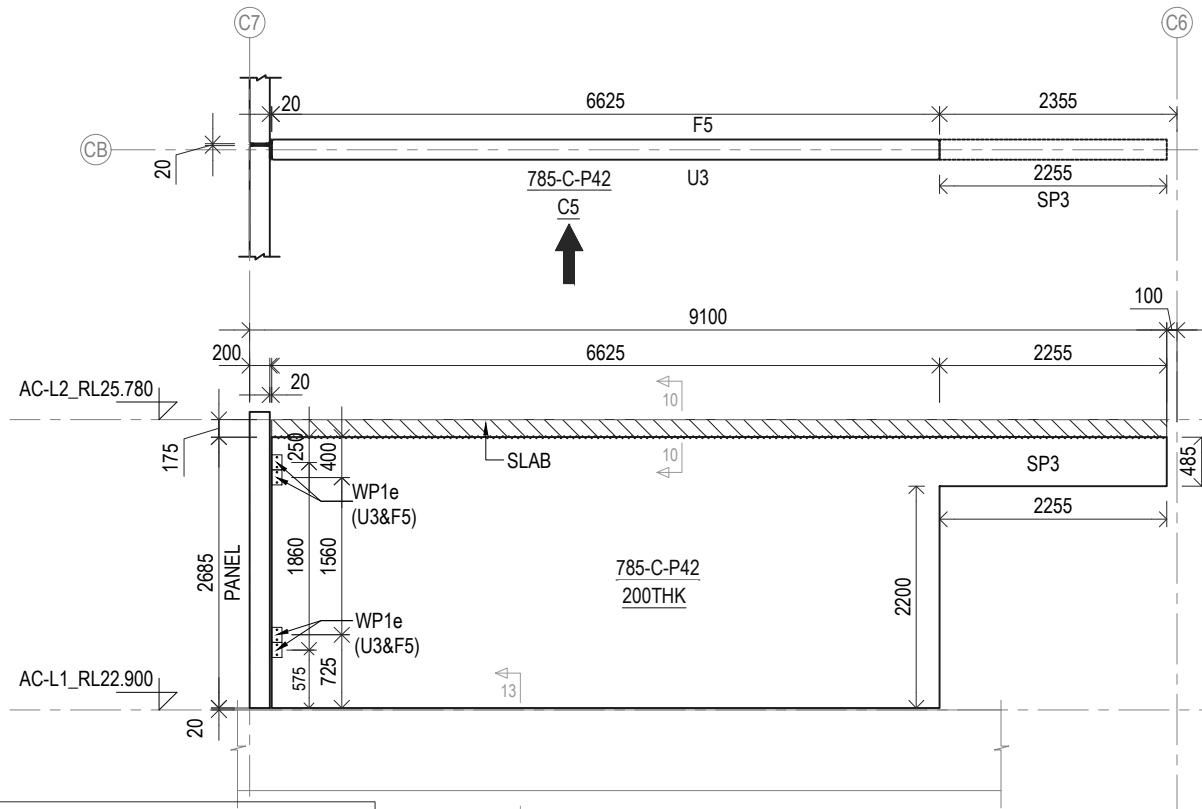

GRID CB/C6-C7 PANEL ELEVATION (ELEVATION-C5)

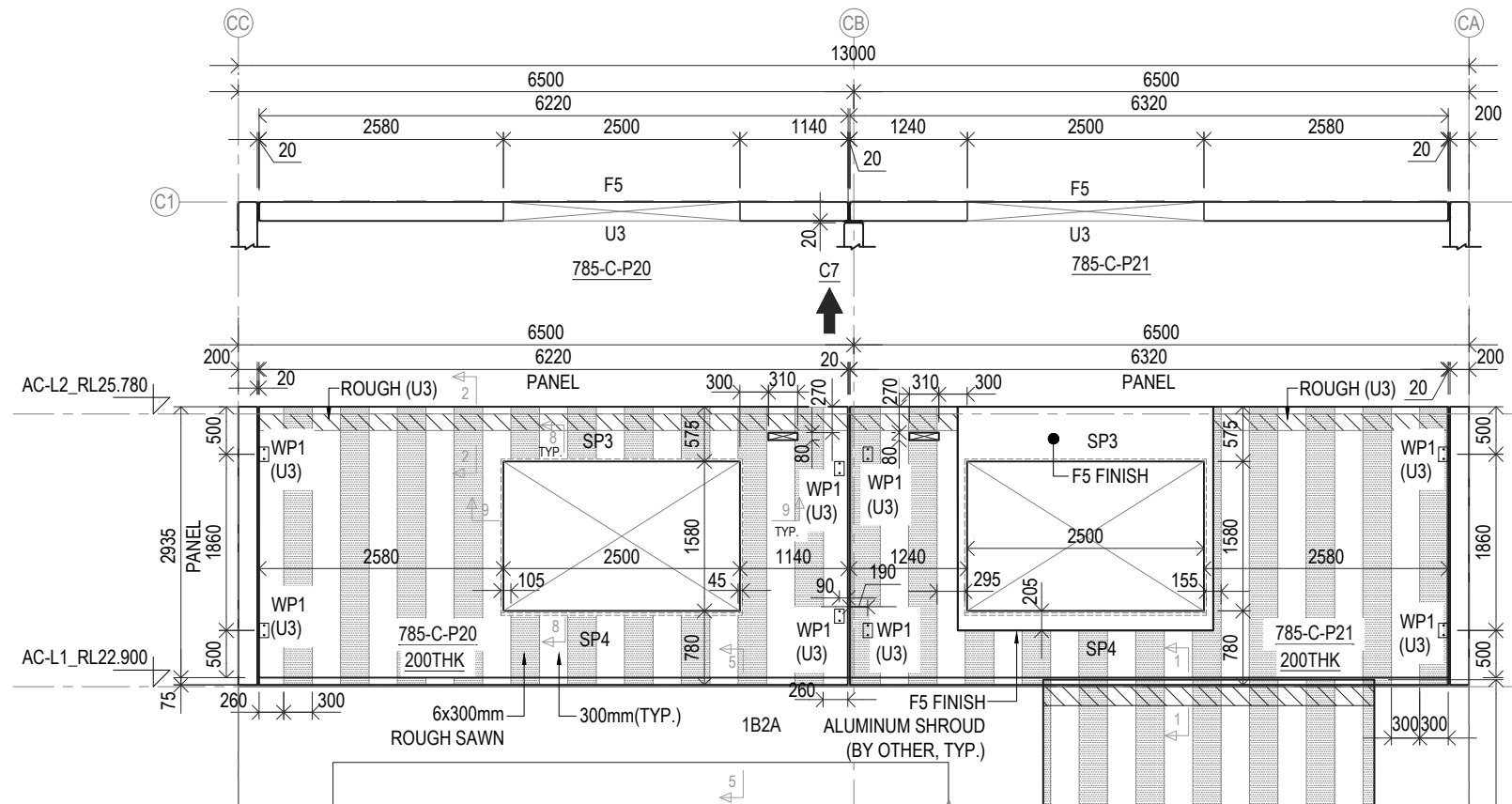

GRID C1 PANEL ELEVATION (ELEVATION-C7)

ENGINEER TO VERIFY BELOW POINTS:-
 1) WELD PLATES LOCATIONS.
 2) TIMBERS FINISHING.
 3) BOTTOM PROFILE OF PANEL.
 4) PANEL HEIGHT CONFIRM.
 5) SP3 & SP4 SIZE CONFIRM.

LEGEND :-
 [Symbol] PRECAST PANEL START
 TBC = TO BE CONFIRM

REV.	DATE	DESCRIPTION	DRAWN	APPROVED
I	28.11.22	REVISED AS PER COMMENTS	SN	
H	02.09.22	REVISED AS PER COMMENTS	JM	
G	27.07.22	REVISED AS PER COMMENTS	AS	
F	25.06.22	REVISED AS PER COMMENTS	AS	

Contractor

Job
MCLEOD GREEN,
 148-162 MCLEOD ROAD, TE ATATU SOUTH

Title
LEVEL 1 PRECAST PANEL ELEVATIONS
BUILDING C

DRAWN	AS	Date	2022	Job No. 785
	HP			
CHECKED		Date	2022	Job No. 785

COPYRIGHT RESERVED

REV.

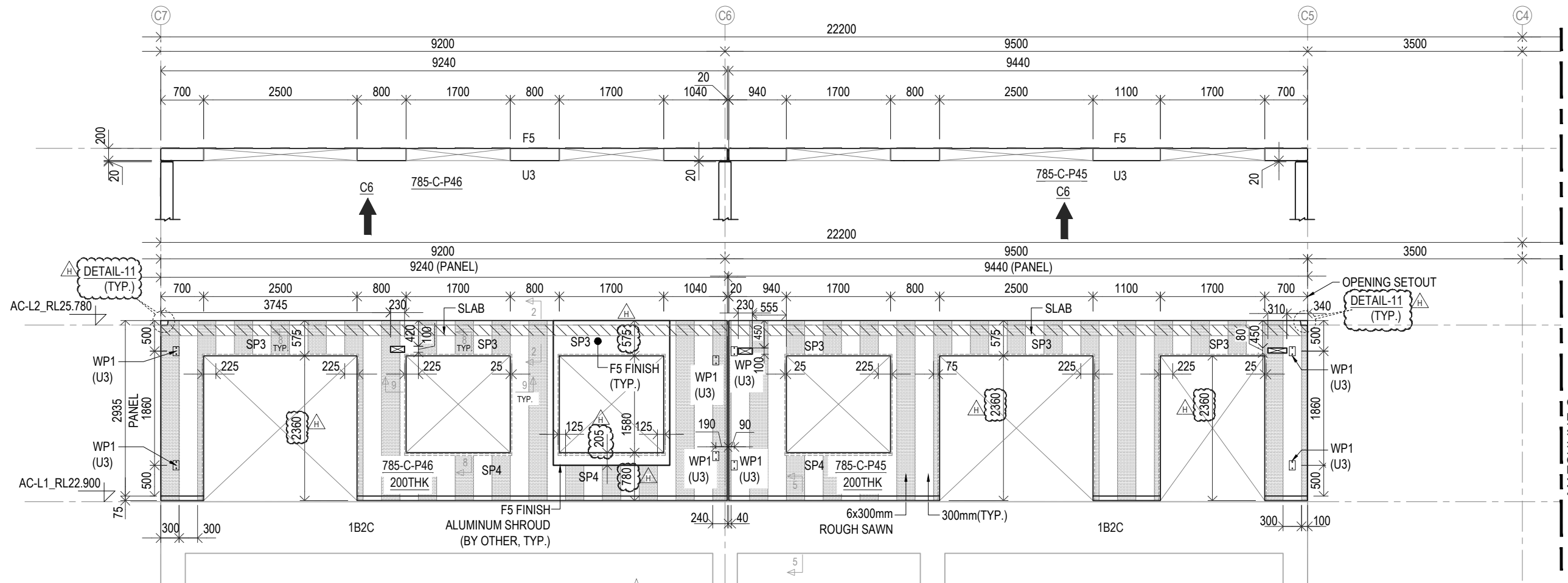

GRID CC PANEL ELEVATION (ELEVATION-C6)

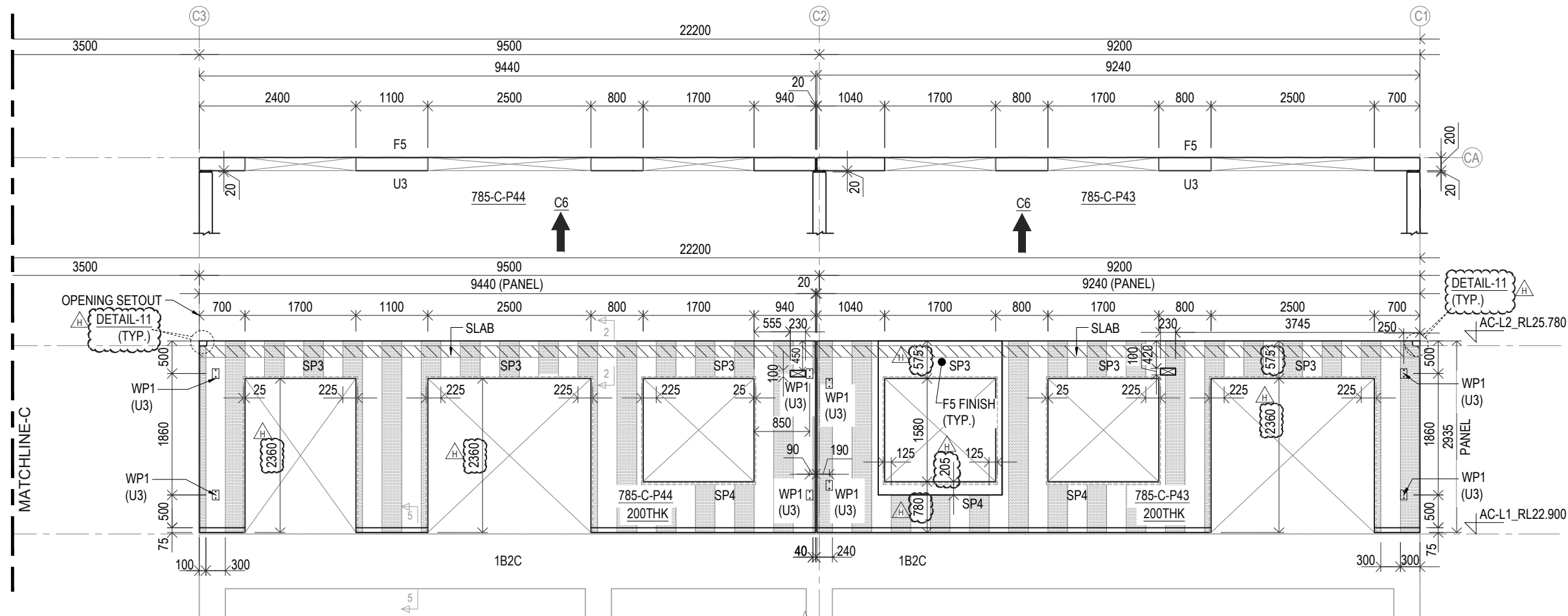

GRID CC PANEL ELEVATION (ELEVATION-C6)

ENGINEER TO VERIFY BELOW POINTS:-
 1) WELD PLATES LOCATIONS.
 2) TIMBERS FINISHING.
 3) BOTTOM PROFILE OF PANEL.
 4) PANEL HEIGHT CONFIRM.
 5) SP3 & SP4 SIZE CONFIRM.

LEGEND :-
 [Symbol] PRECAST PANEL START
 TBC = TO BE CONFIRM

REV.	DATE	DESCRIPTION	DRAWN	APPROVED
H	02.09.22	REVISED AS PER COMMENTS	JM	
G	27.07.22	REVISED AS PER COMMENTS	AS	
F	25.06.22	REVISED AS PER COMMENTS	AS	
E	18.06.22	REVISED AS PER COMMENTS	AS	

Contractor

Job
 MCLEOD GREEN,
 148-162 MCLEOD ROAD, TE ATATU SOUTH

Title
 LEVEL 1 PRECAST PANEL ELEVATIONS
 BUILDING C

COPYRIGHT
 RESERVED

Drawn	AS	Date	2022	Job No.	785
Checked	HP	Scale (A3)	1:75	Dwg No.	11 H REV.

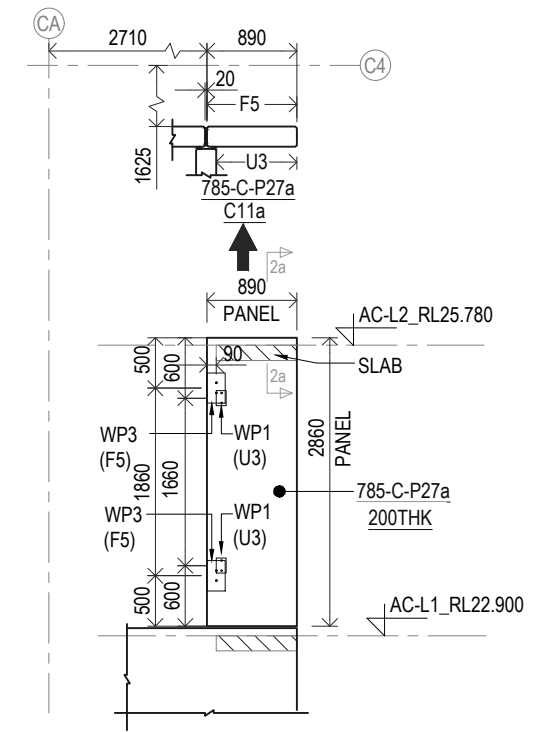
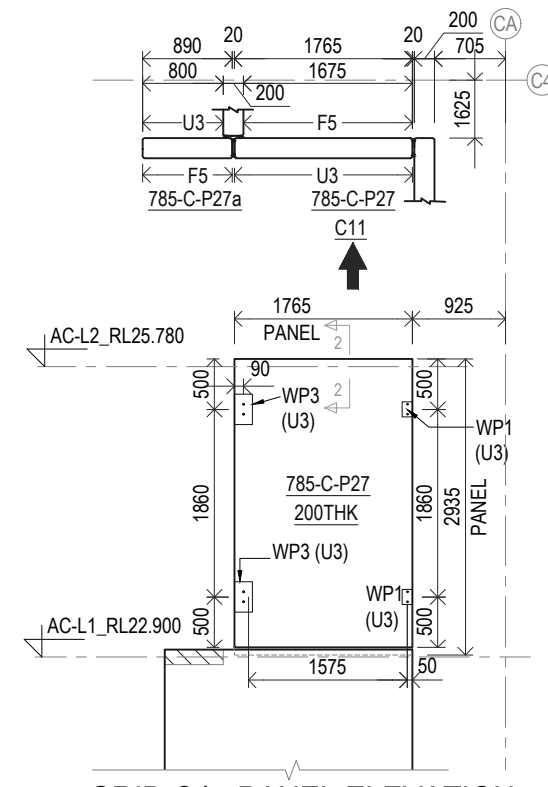
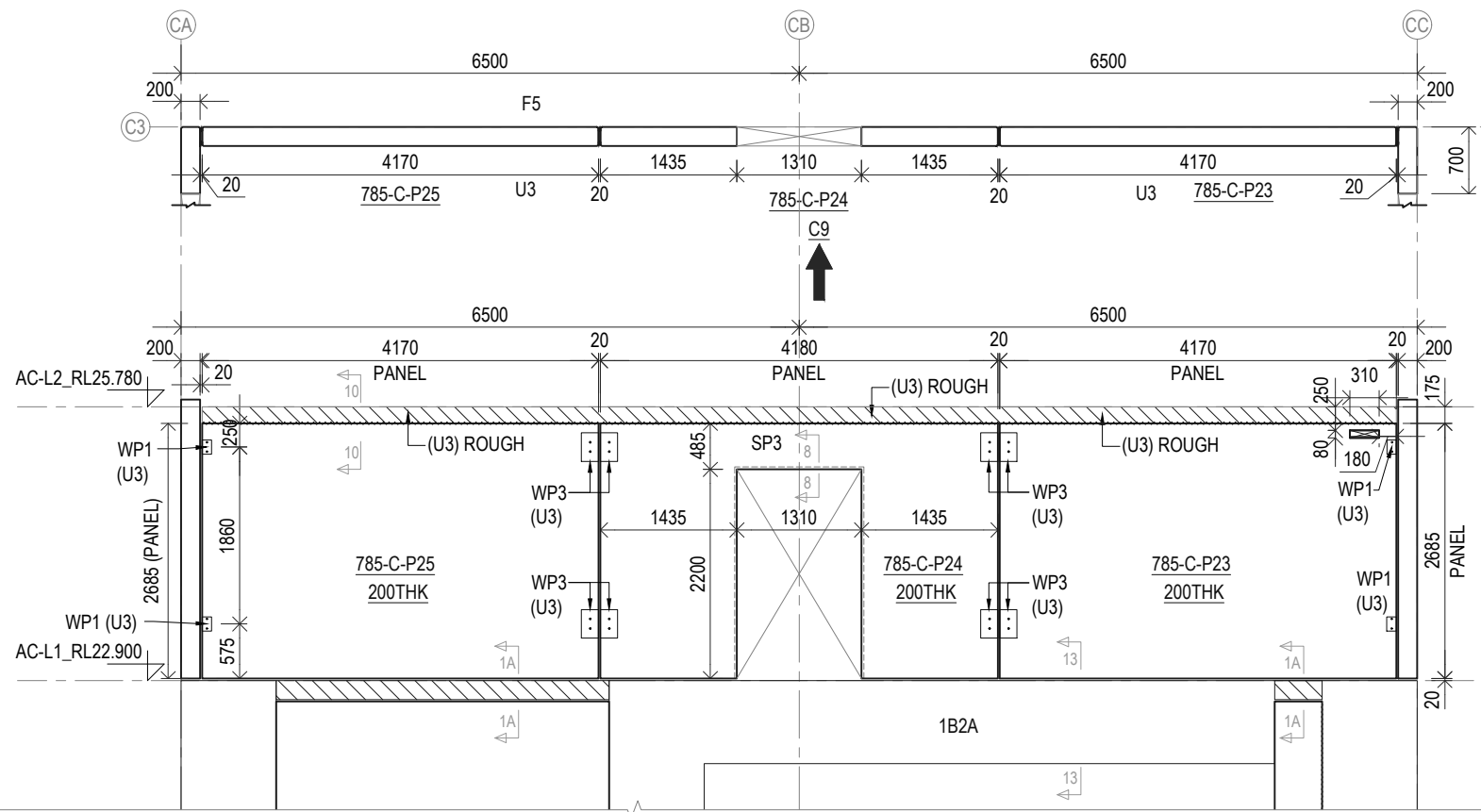
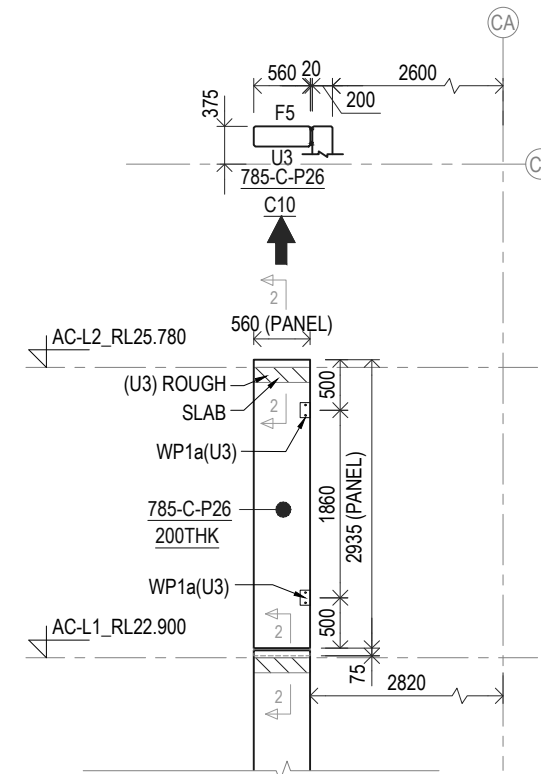
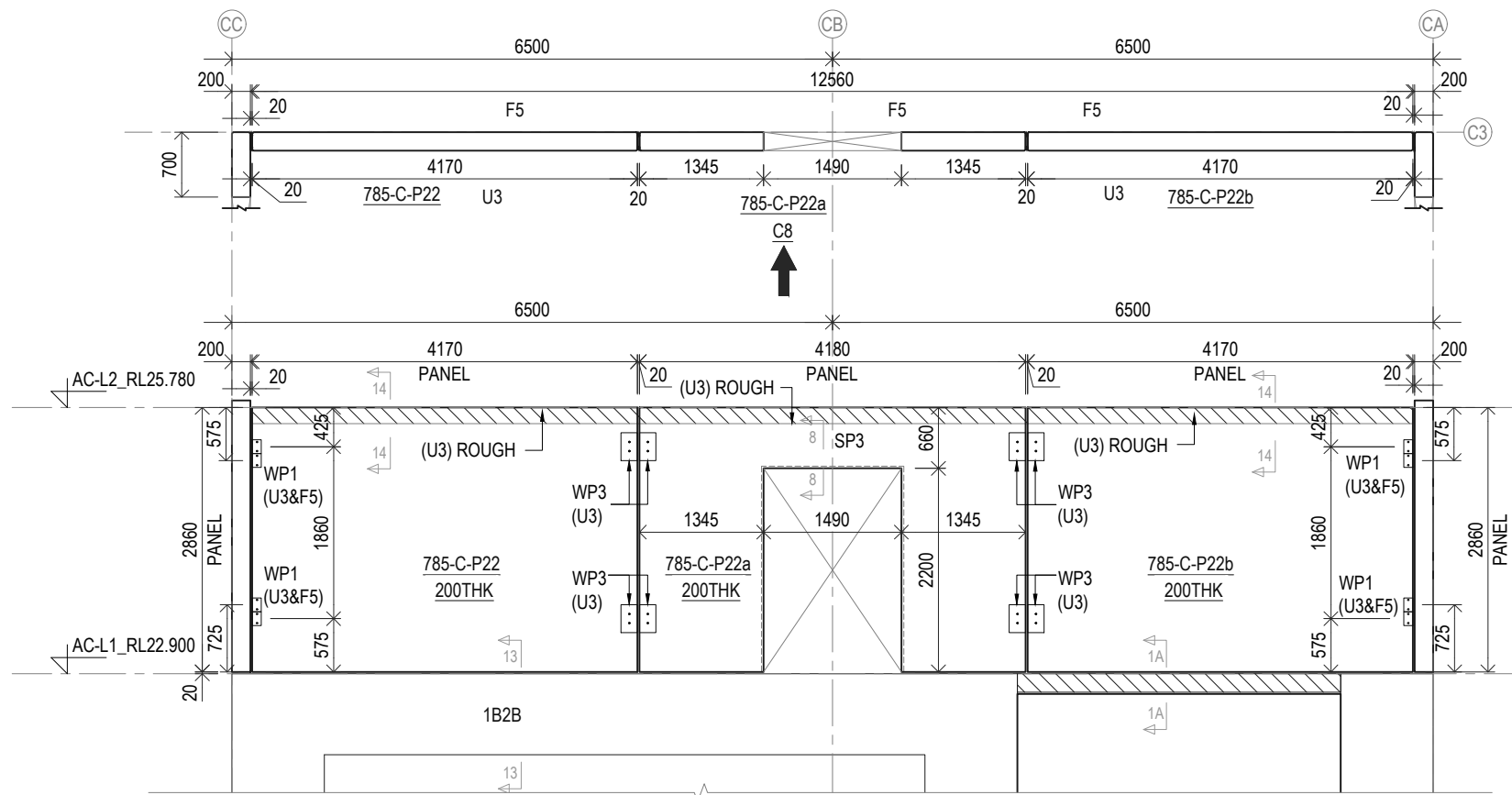

GRID C4+ PANEL ELEVATION (ELEVATION-C11a)

ENGINEER TO VERIFY BELOW POINTS:-
 1) WELD PLATES LOCATIONS.
 2) TIMBERS FINISHING.
 3) BOTTOM PROFILE OF PANEL.
 4) PANEL HEIGHT CONFIRM.
 5) SP3 & SP4 SIZE CONFIRM.

LEGEND :-
 [Symbol] PRECAST PANEL START
 TBC = TO BE CONFIRM

REV.	DATE	DESCRIPTION	DRAWN	APPROVED
I	28.11.22	REVISED AS PER COMMENTS	SN	
H	02.09.22	REVISED AS PER COMMENTS	JM	
G	27.07.22	REVISED AS PER COMMENTS	AS	
F	25.06.22	REVISED AS PER COMMENTS	AS	

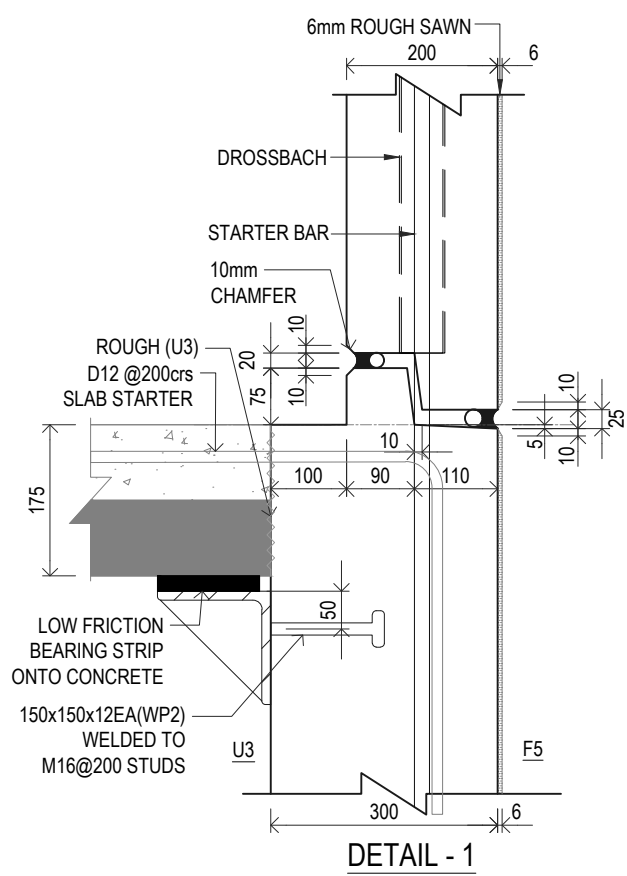

DETAIL - 1

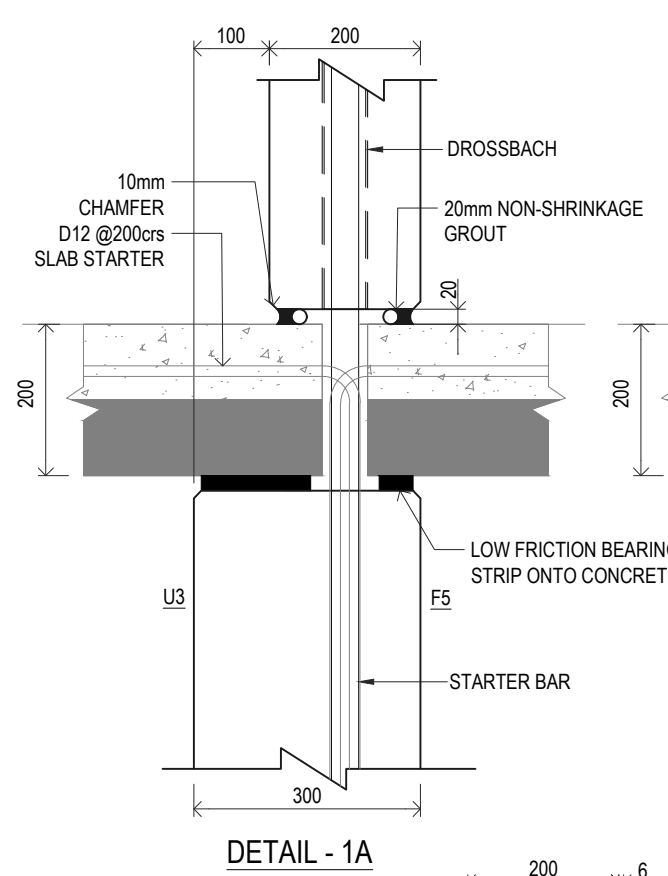

DETAIL - 1A

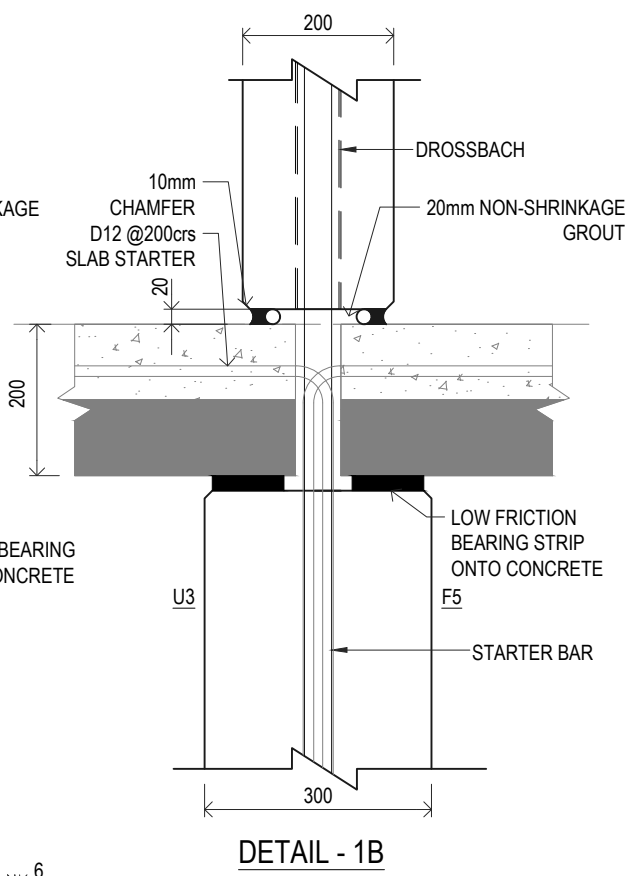

DETAIL - 1B

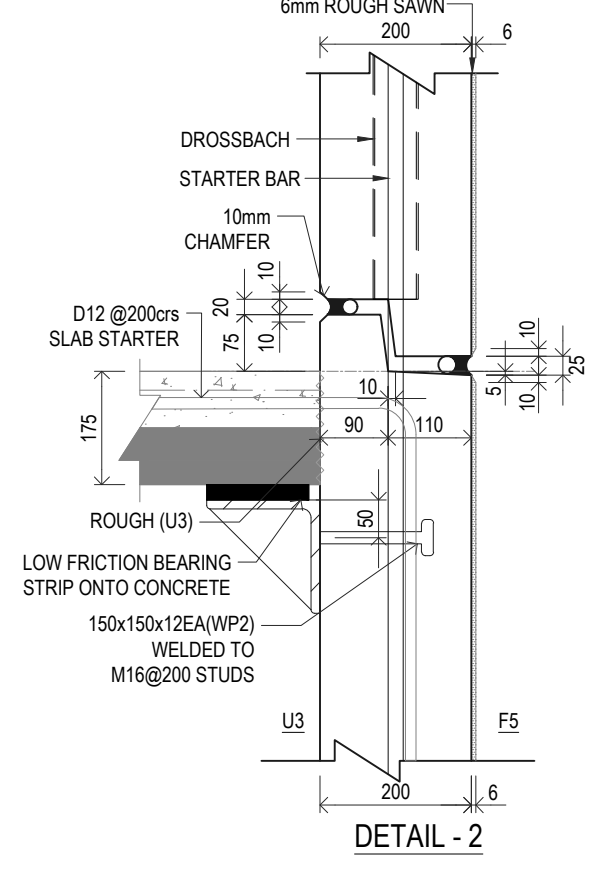

DETAIL - 2

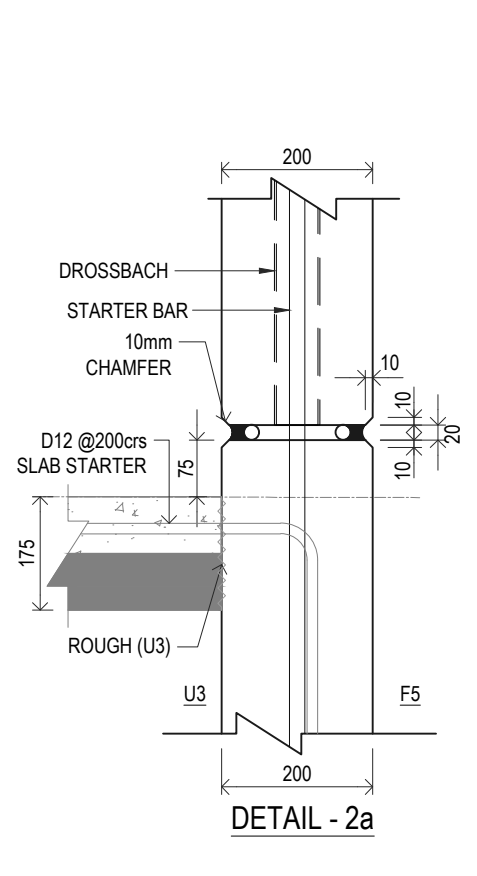

DETAIL - 2a

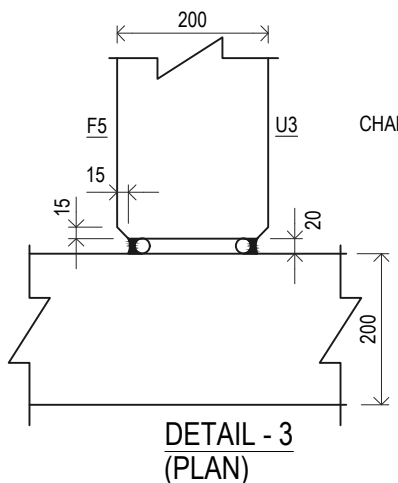

DETAIL - 3 (PLAN)

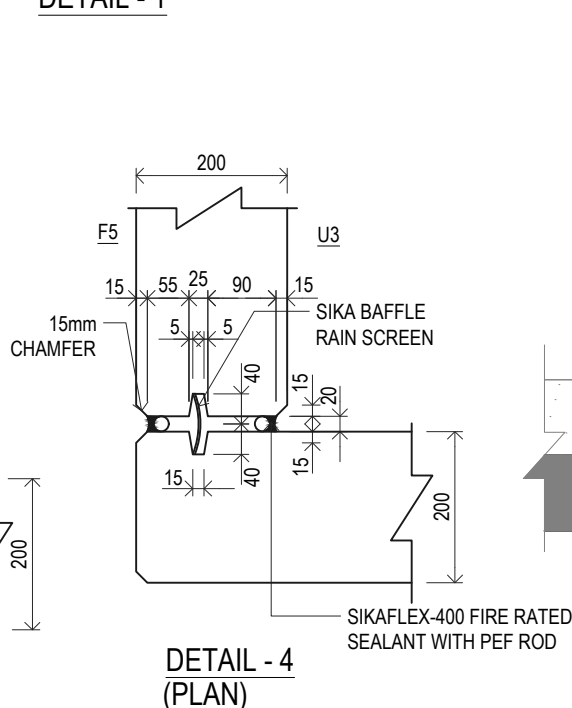

DETAIL - 4 (PLAN)

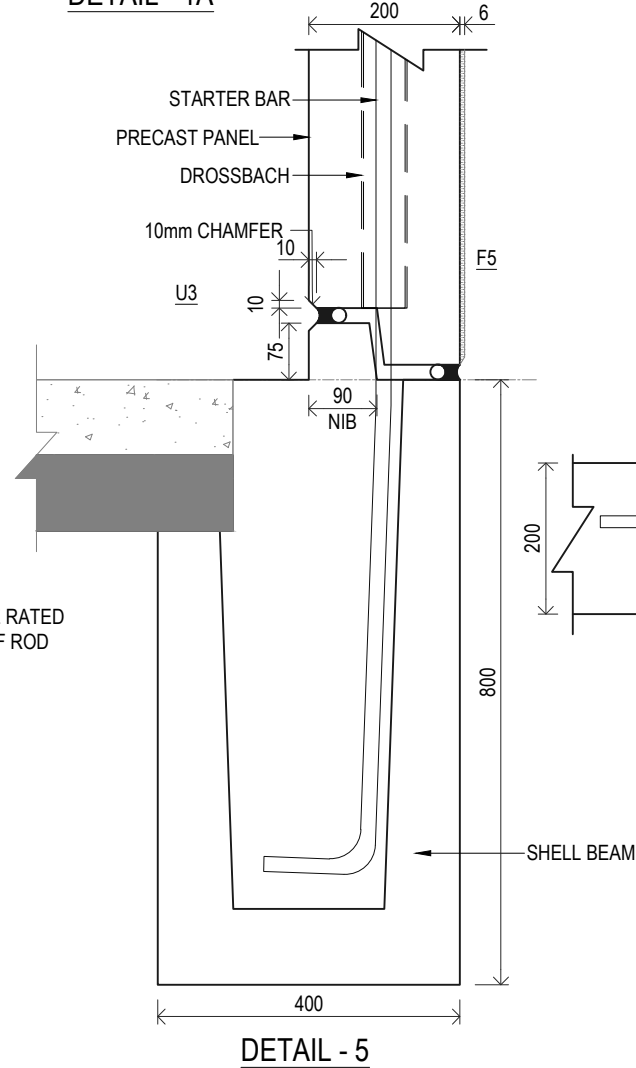

DETAIL - 5

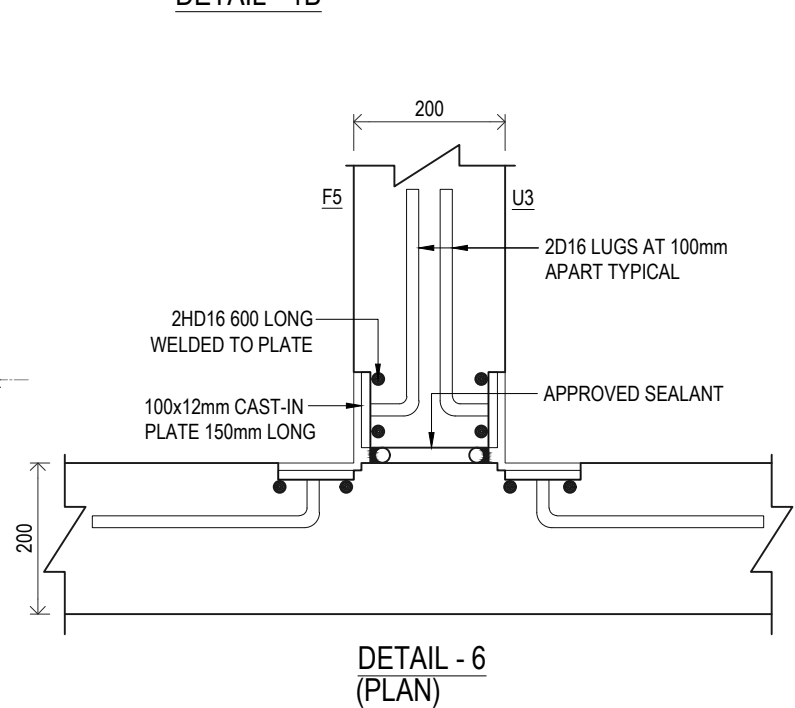

DETAIL - 6 (PLAN)

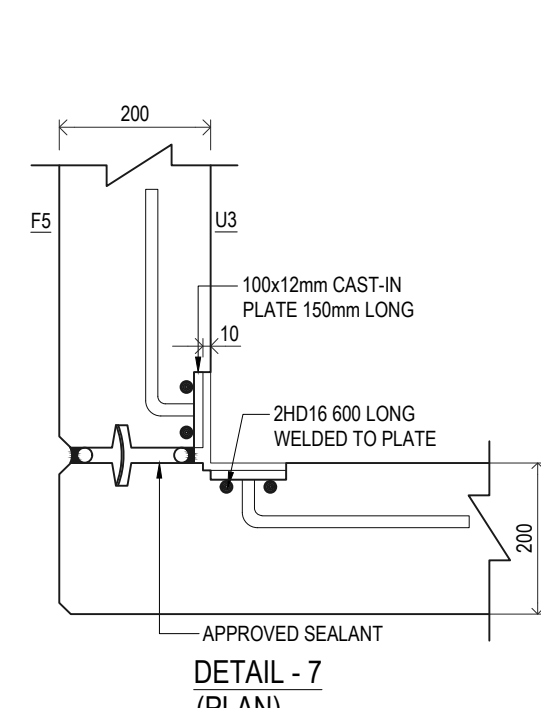

DETAIL - 7 (PLAN)

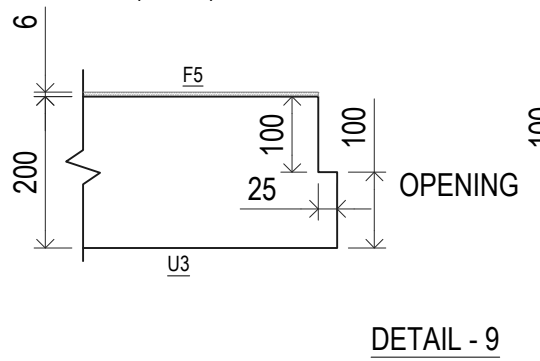

DETAIL - 9

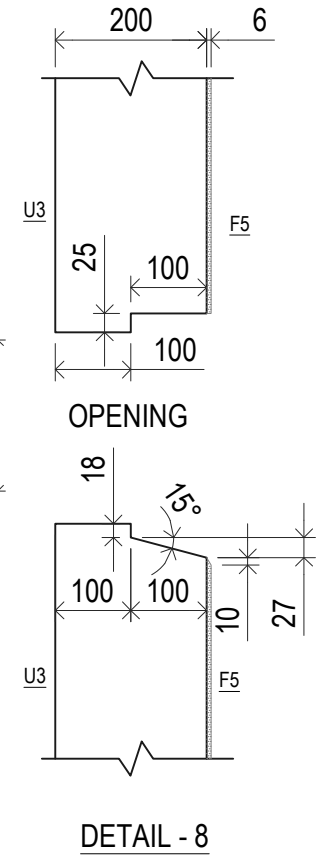

DETAIL - 8

REV.	DATE	DESCRIPTION	DRAWN	APPROVED
G	27.07.22	REVISED AS PER COMMENTS	AS	
F	25.06.22	REVISED AS PER COMMENTS	AS	
E	18.06.22	REVISED AS PER COMMENTS	AS	
D	04.06.22	REVISED AS PER COMMENTS	AS	

LEGEND :-
TBC = TO BE CONFIRM

Contractor	Job	MCLEOD GREEN, 148-162 MCLEOD ROAD, TE ATATU SOUTH	Title	LEVEL 1 PRECAST PANEL JOINT DETAILS BUILDING C	Copyright Reserved	Drawn	AS	Date	2022	Job No.	785
						Checked	HP	Scale (A3)	1:10	Dwg No.	14

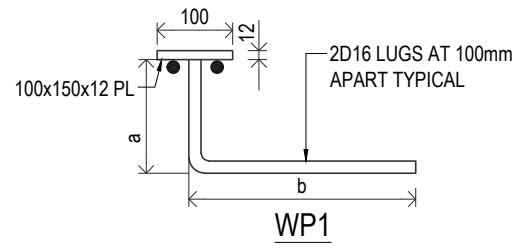
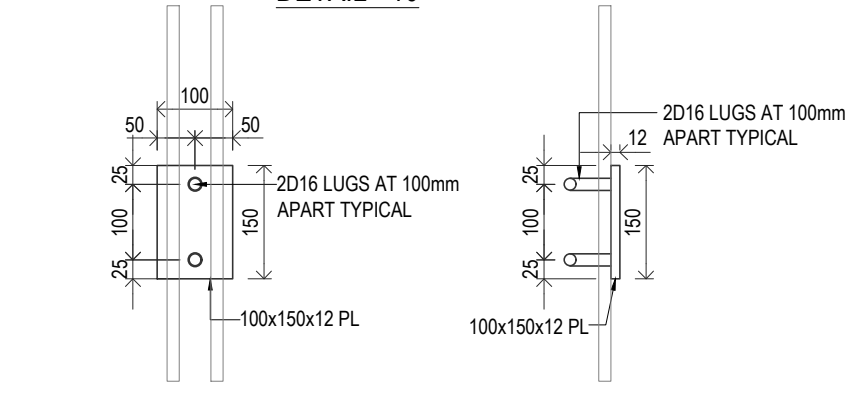
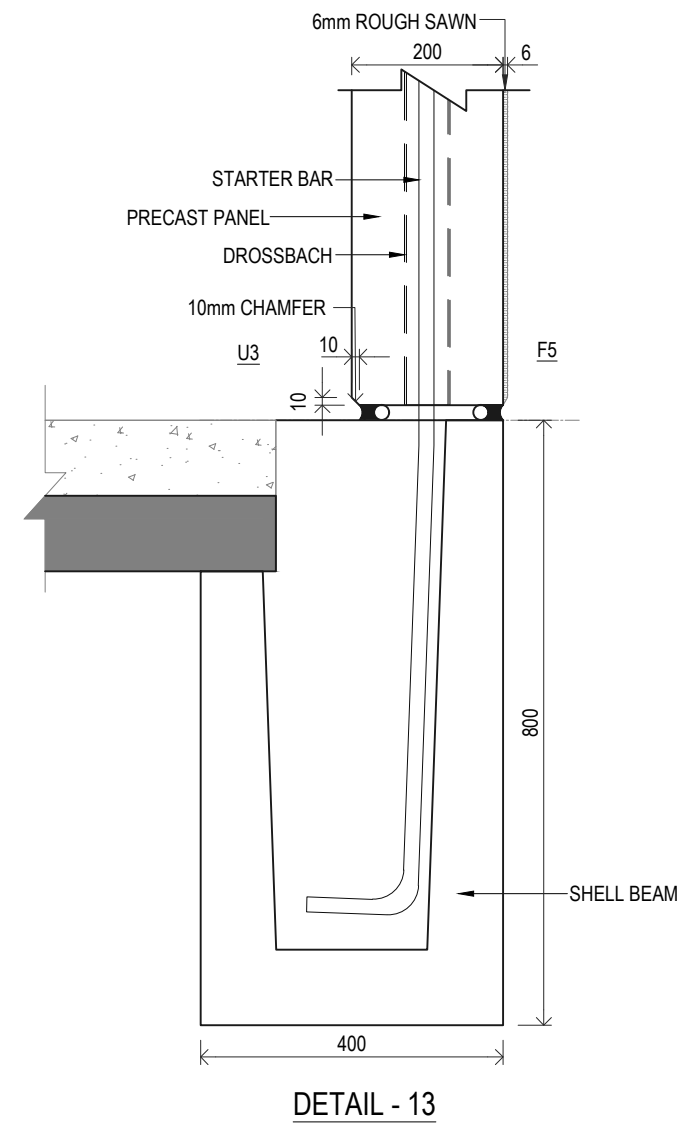
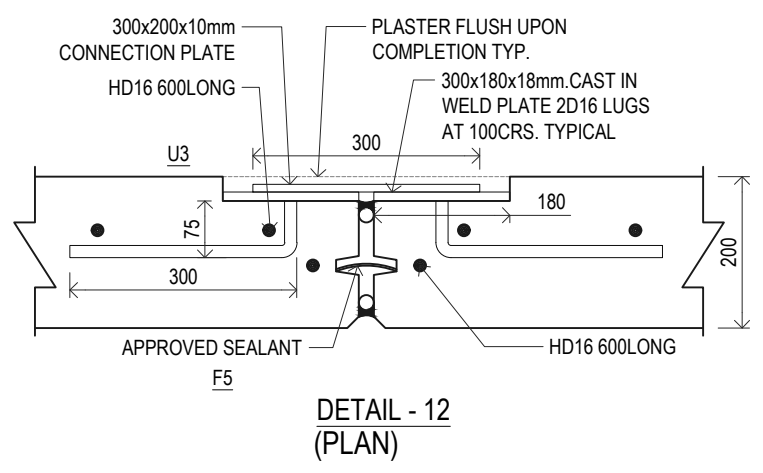
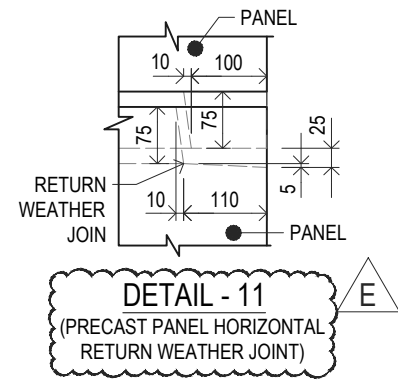
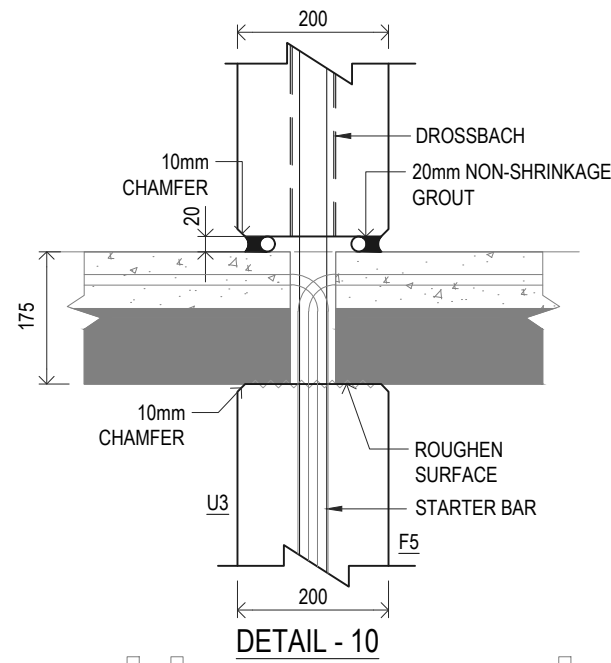

100X12 CAST-IN PLATE
150MM LONG

WELDED PLATE(WP)	a	b
WP1	150	300
WP1a	150	230
WP1b	150	215
WP1c	150	145
WP1d	175	300
WP1e	135	300

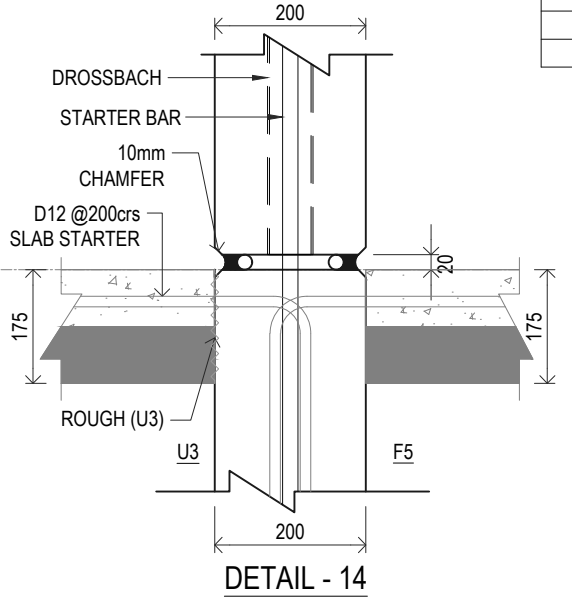
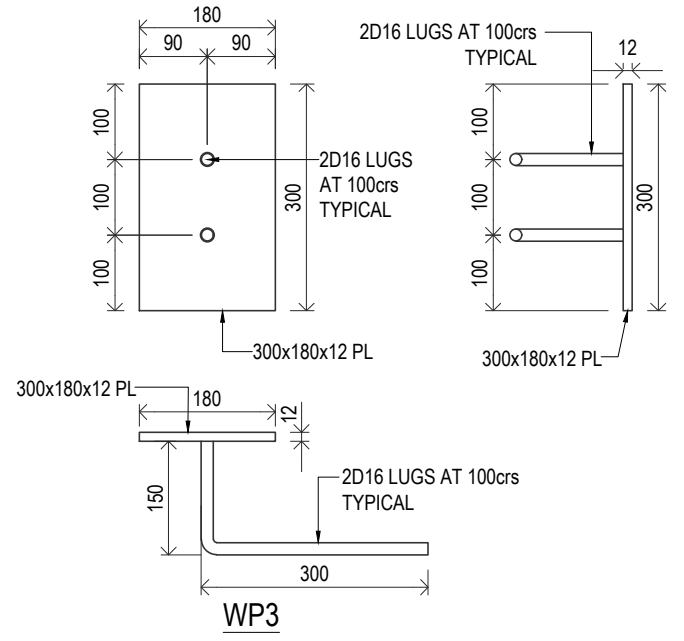
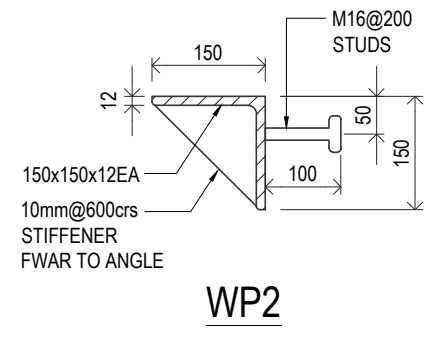

REV.	DATE	DESCRIPTION	DRAWN	APPROVED
E	02.09.22	REVISED AS PER COMMENTS	JM	
D	27.07.22	REVISED AS PER COMMENTS	AS	
C	25.06.22	REVISED AS PER COMMENTS	AS	
B	18.06.22	REVISED AS PER COMMENTS	AS	
A	04.06.22	FOR APPROVAL	AS	

LEGEND :-
TBC = TO BE CONFIRM

Contractor
Job **MCLEOD GREEN,**
148-162 MCLEOD ROAD, TE ATATU SOUTH

Title
LEVEL 1 PRECAST PANEL JOINT DETAILS
BUILDING C

COPYRIGHT RESERVED	Drawn	AS	Date	2022	Job No. 785
	Checked	HP	Scale (A3)	1:10	34 E Dwg No. REV.

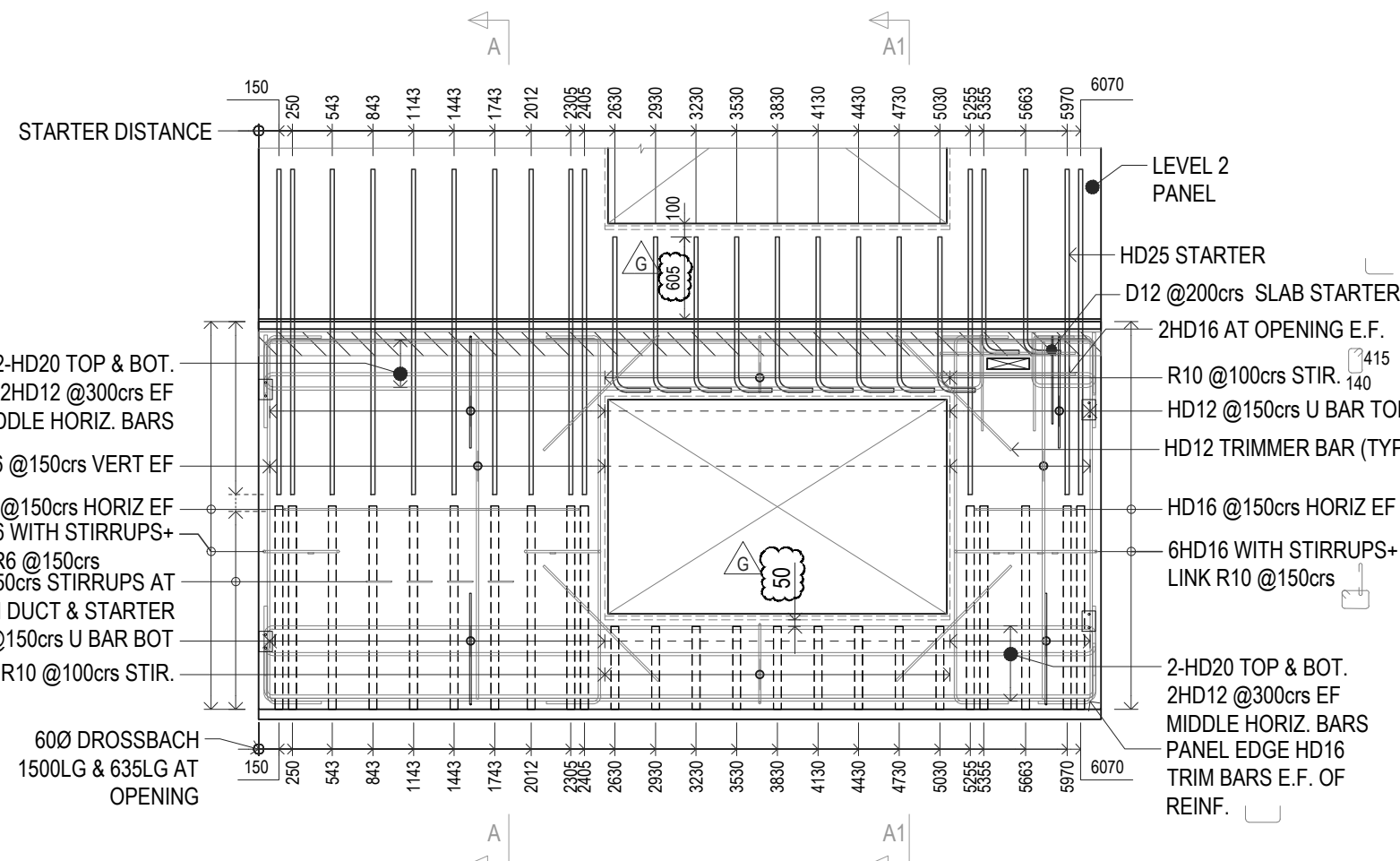

REO LAYOUT
SCALE 1:50
VIEW FROM INSIDE

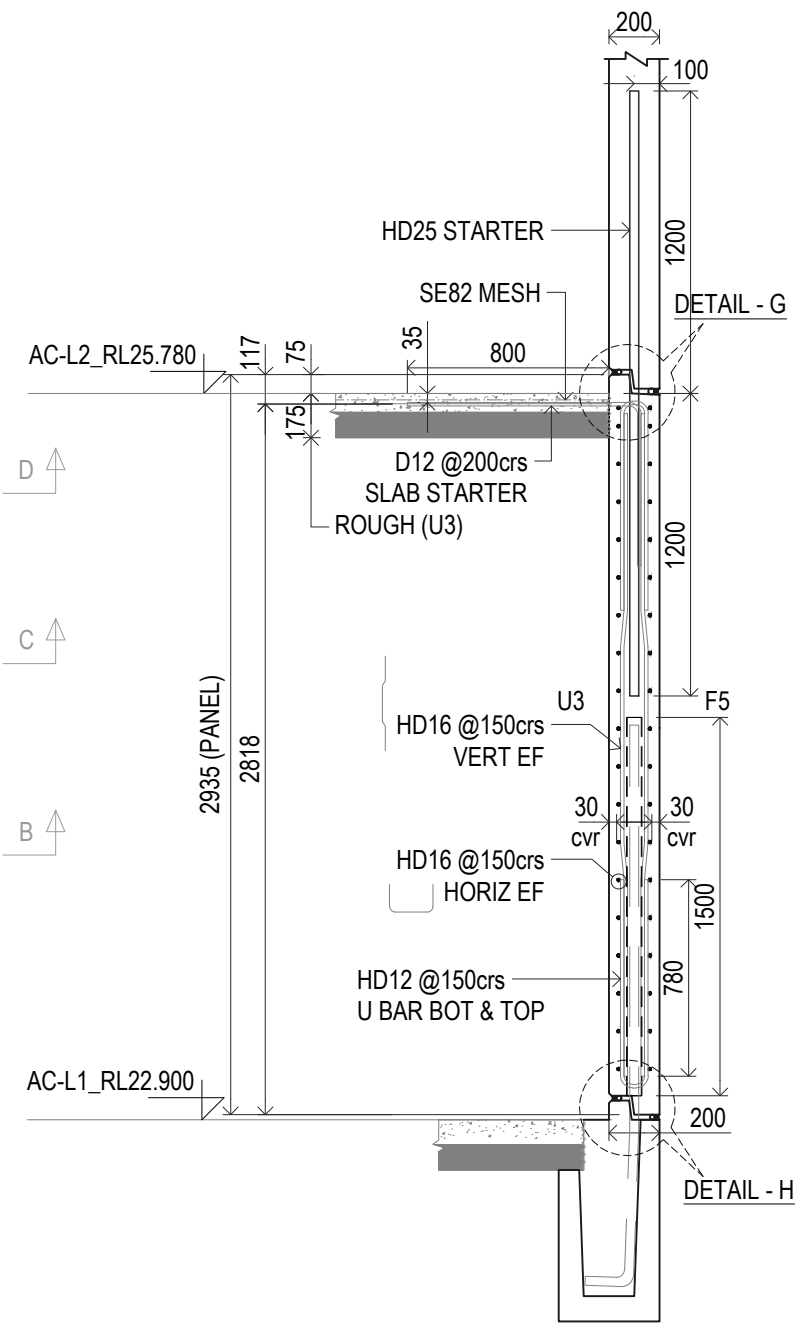

SECTION A-A
SCALE 1:30

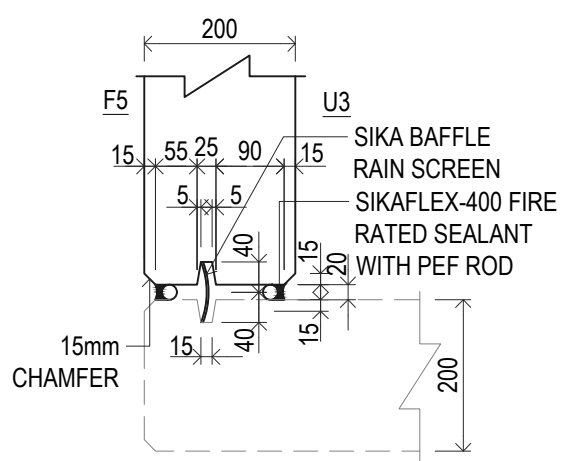
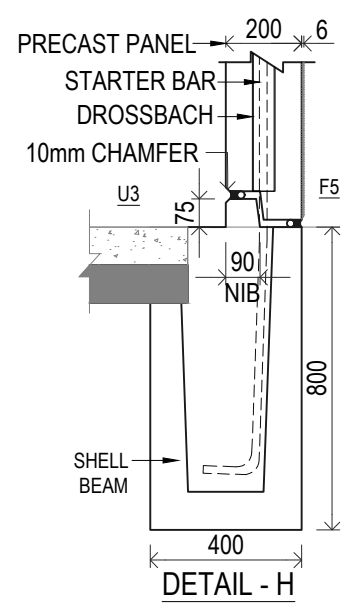
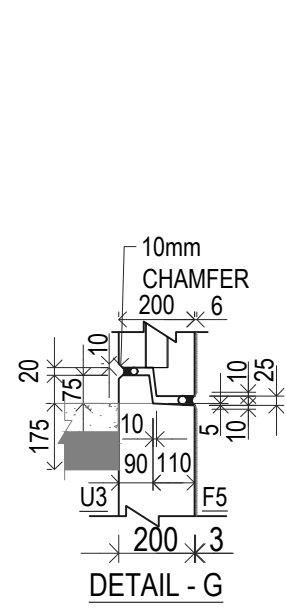

DETAIL - M
(PRECAST PANEL JOINT
PLAN DETAIL FOR
GROOVE AT EDGE)

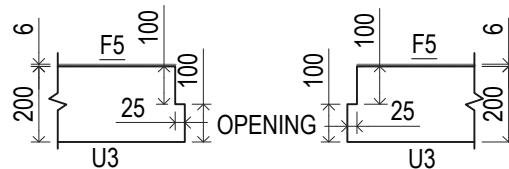

DETAIL - E

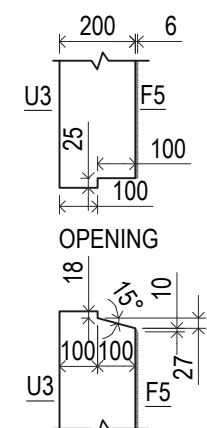

DETAIL - F

SHEET 1 OF 2
T.B.C. = TO BE CONFIRM

INSPECTION & TEST PLAN	
INSPECTED BY	
NAME OF FABRICATOR	
UNIT NO.	
CAST DATE	
CAST TIME	
CONCRETE DOCKET NO.	
CONCRETE SPECIF. (MPa)	

ITEM	FABRICATOR INITIAL	APPROVED Y / N
MOULD CLEANLINESS		
RELEASE OIL		
DIMENSIONS		
FORMWORK FIXED		
OPENING / REBATES CORRECT & POSITION		
HOLD POINT		
REINFORCING CORRECT		
LAPS & SPLICES CORRECT		
SPACING & COVER CORRECT		
HOLD POINT		
LIFTERS POSITIONED CORRECTLY		
CAST - IN ITEMS		
STARTERS, LACING BARS		
APPROVED FOR CASTING		

POST POUR INSPECTION	
INSPECTED BY	
DATE	
ITEM	APPROVED Y / N
SWIFTLIFTS POSITION	
SWIFTLIFTS RECESS CLEANED	
CAST-IN ITEMS CLEANED	
CONCRETE FINISH	
LABELED (NUMBER / DATED)	
DAMAGE (CRACKS / CHIPPING)	
CLEANLINESS	
ANY ACTION REQUIRED:	
APPROVED FOR DISPATCH	

SLING ANGLE TO BE NOT LESS THAN 60° TO HORIZONTAL WHEN LIFTING

30 cvr TO ALL EDGES AND FACES (UNO) 30Mpa Concrete

CAST IN SUNDRY
60Ø DROSSBACH 1500LG = 15
60Ø DROSSBACH 635LG = 09
7HPAWF(LIFTING HOOK) = 4
WP1-L = 2
WP1-R = 2

AREA (m ²)	14.0880
VOLUME (m ³)	2.82
WEIGHT (t)	7.33
THICKNESS (mm)	200
CONC. GRADE	30MPa
FINISH MF/NF	F5/U3
NO: OFF	1

REV.	DATE	DESCRIPTION	DRAWN	APPROVED
G	18.10.22	DROSSBACH HEIGHT REVISED AT WINDOW	JM	
F	02.09.22	REVISED AS PER COMMENTS	JM	
E	27.07.22	REVISED AS PER COMMENTS	AS	
D	25.06.22	REVISED AS PER COMMENTS	AS	
C	18.06.22	REVISED AS PER COMMENTS	AS	

Contractor

Job
MCLEOD GREEN,
148-162 MCLEOD ROAD, TE ATATU SOUTH

Title
785-C-P20
BUILDING C

Drawn	AS	Date	2022	Job No.	785
Checked	PS	Scale (A3)	1:50/1:30	Dwg No.	C-P120/01

COPYRIGHT RESERVED

REV.

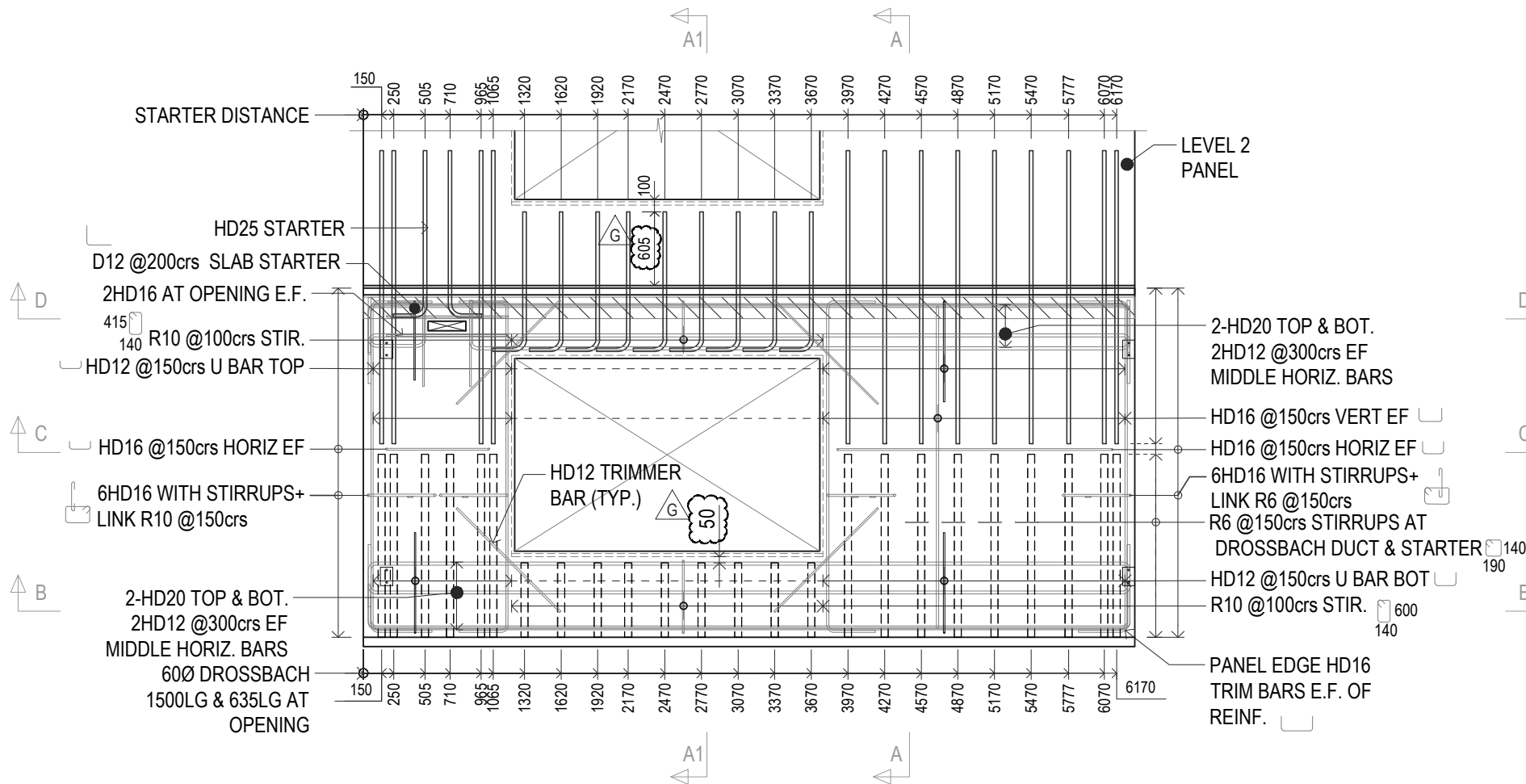
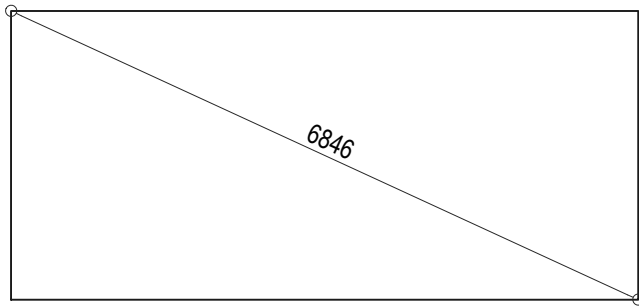

REO LAYOUT

SCALE 1:50

VIEW FROM INSIDE

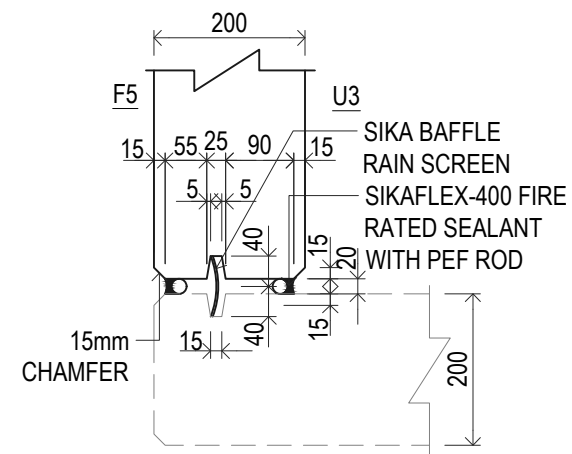

DETAIL - M
(PRECAST PANEL JOINT
PLAN DETAIL FOR
GROOVE AT EDGE)

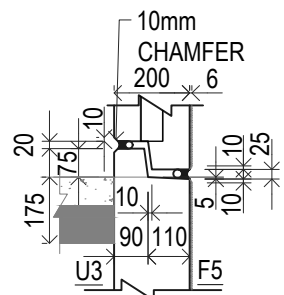

DETAIL - G

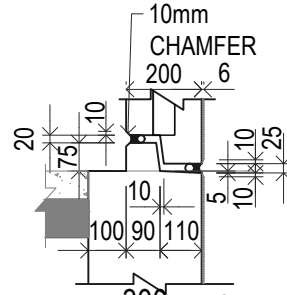

DETAIL - L



DETAIL - E

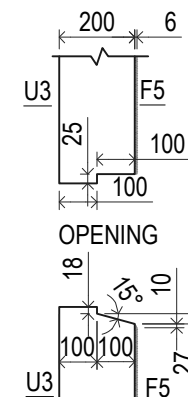

DETAIL - F

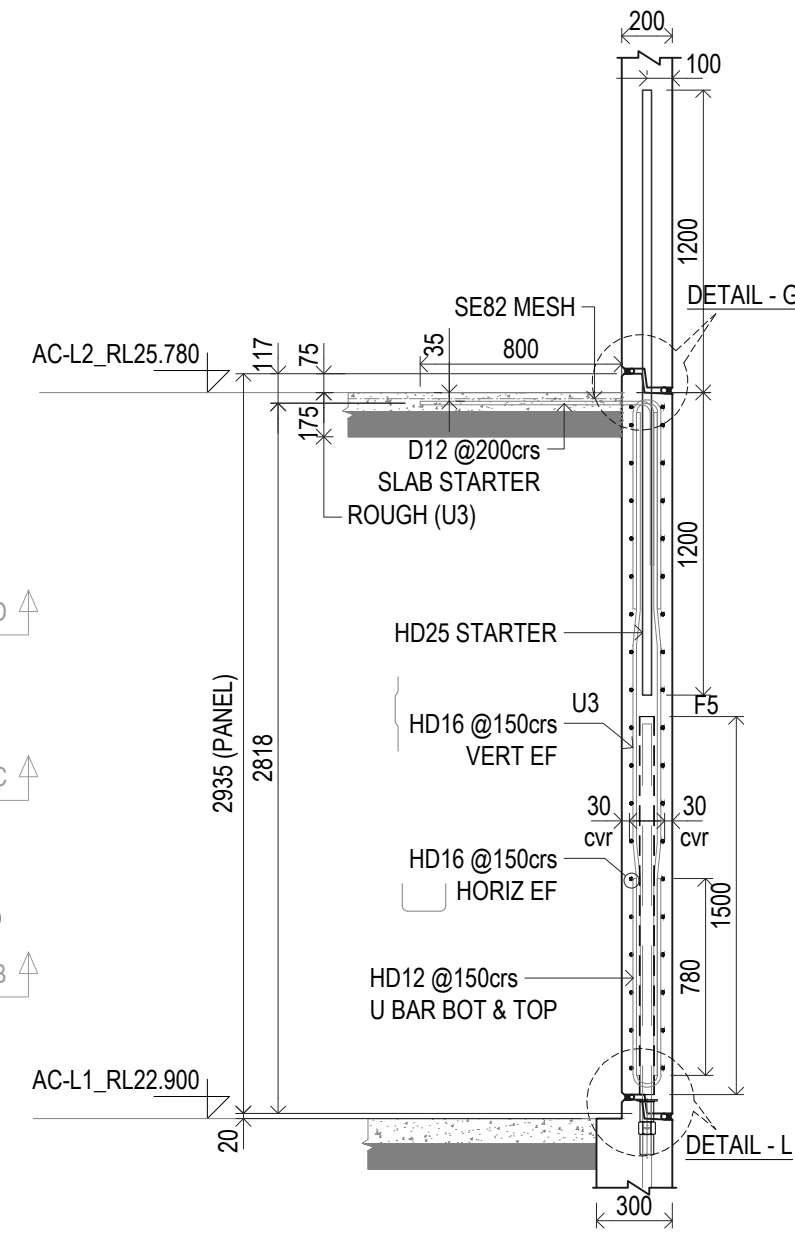

SECTION A-A

SCALE 1:30

INSPECTION & TEST PLAN		
INSPECTED BY		
NAME OF FABRICATOR		
UNIT NO.		
CAST DATE		
CAST TIME		
CONCRETE DOCKET NO.		
CONCRETE SPECIF. (MPa)		
ITEM	FABRICATOR INITIAL	APPROVED Y / N
MOULD CLEANLINESS		
RELEASE OIL		
DIMENSIONS		
FORMWORK FIXED		
OPENING / REBATES CORRECT & POSITION		
HOLD POINT		
REINFORCING CORRECT		
LAPS & SPLICES CORRECT		
SPACING & COVER CORRECT		
HOLD POINT		
LIFTERS POSITIONED CORRECTLY		
CAST - IN ITEMS		
STARTERS, LACING BARS		
APPROVED FOR CASTING		

POST POUR INSPECTION	
INSPECTED BY	
DATE	
ITEM	APPROVED Y / N
SWIFTLIFTS POSITION	
SWIFTLIFTS RECESS CLEANED	
CAST-IN ITEMS CLEANED	
CONCRETE FINISH	
LABELED (NUMBER / DATED)	
DAMAGE (CRACKS / CHIPPING)	
CLEANLINESS	
ANY ACTION REQUIRED:	
APPROVED FOR DISPATCH	

SLING ANGLE TO BE NOT LESS THAN 60° TO HORIZONTAL WHEN LIFTING

30 cvr TO ALL EDGES AND FACES (UNO) 30Mpa Concrete

CAST IN SUNDRY
 60Ø DROSSBACH 1500LG = 15
 60Ø DROSSBACH 635LG = 09
 7HPAWF(LIFTING HOOK) = 4
 WP1-L = 2
 WP1-R = 2

AREA (m ²)	14.0880
VOLUME (m ³)	2.82
WEIGHT (t)	7.33
THICKNESS (mm)	200
CONC. GRADE	30MPa
FINISH MF/NF	F5/U3
NO: OFF	1

REV.	DATE	DESCRIPTION	DRAWN	APPROVED
G	18.10.22	DROSSBACH HEIGHT REVISED AT WINDOW	JM	
F	02.09.22	REVISED AS PER COMMENTS	JM	
E	27.07.22	REVISED AS PER COMMENTS	AS	
D	25.06.22	REVISED AS PER COMMENTS	AS	
C	18.06.22	REVISED AS PER COMMENTS	AS	

SHEET 1 OF 2

T.B.C. = TO BE CONFIRM

Contractor	Job	Title	Scale	Date	Year	Job No.	Rev.
	MCLEOD GREEN, 148-162 MCLEOD ROAD, TE ATATU SOUTH	785-C-P21 BUILDING C	1:50/1:30	2022	2022	785	G
			Scale (A3)	1:50/1:30		C-P121/01	G
			Checked	PS	Dwg No.		REV.

COPYRIGHT RESERVED

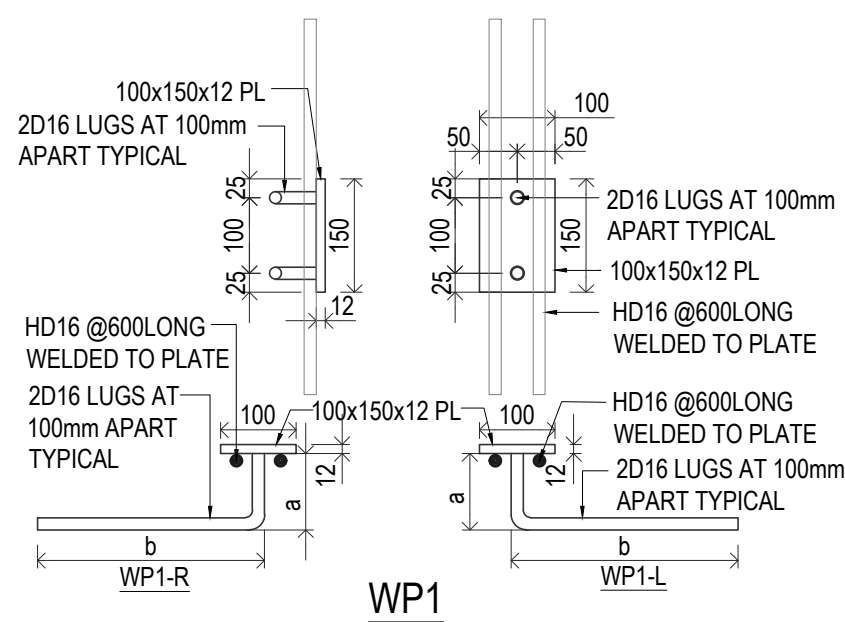
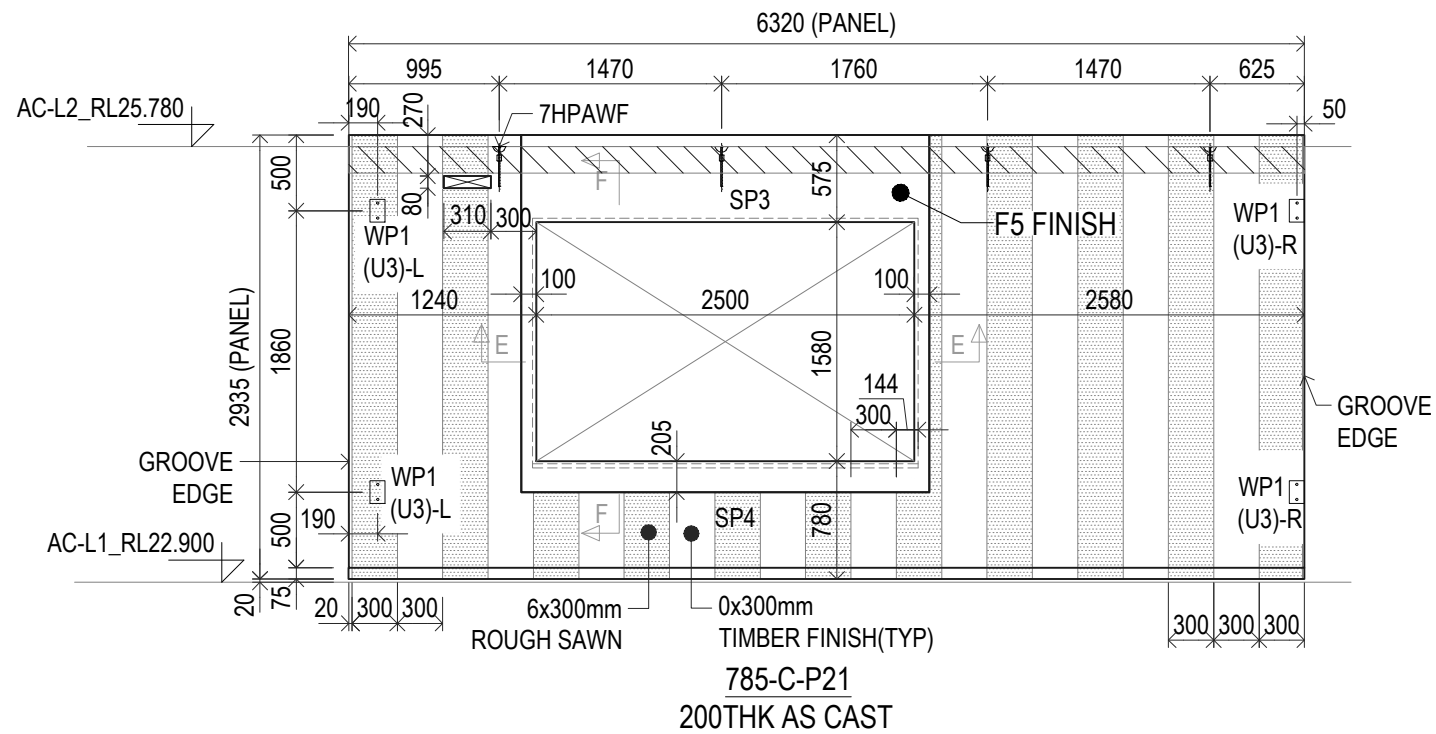

100X12 CAST-IN PLATE
150MM LONG

WELDED PLATE(WP)	a	b
WP1	150	300
WP1a	150	230
WP1b	150	215
WP1c	150	145
WP1d	175	300
WP1e	135	300

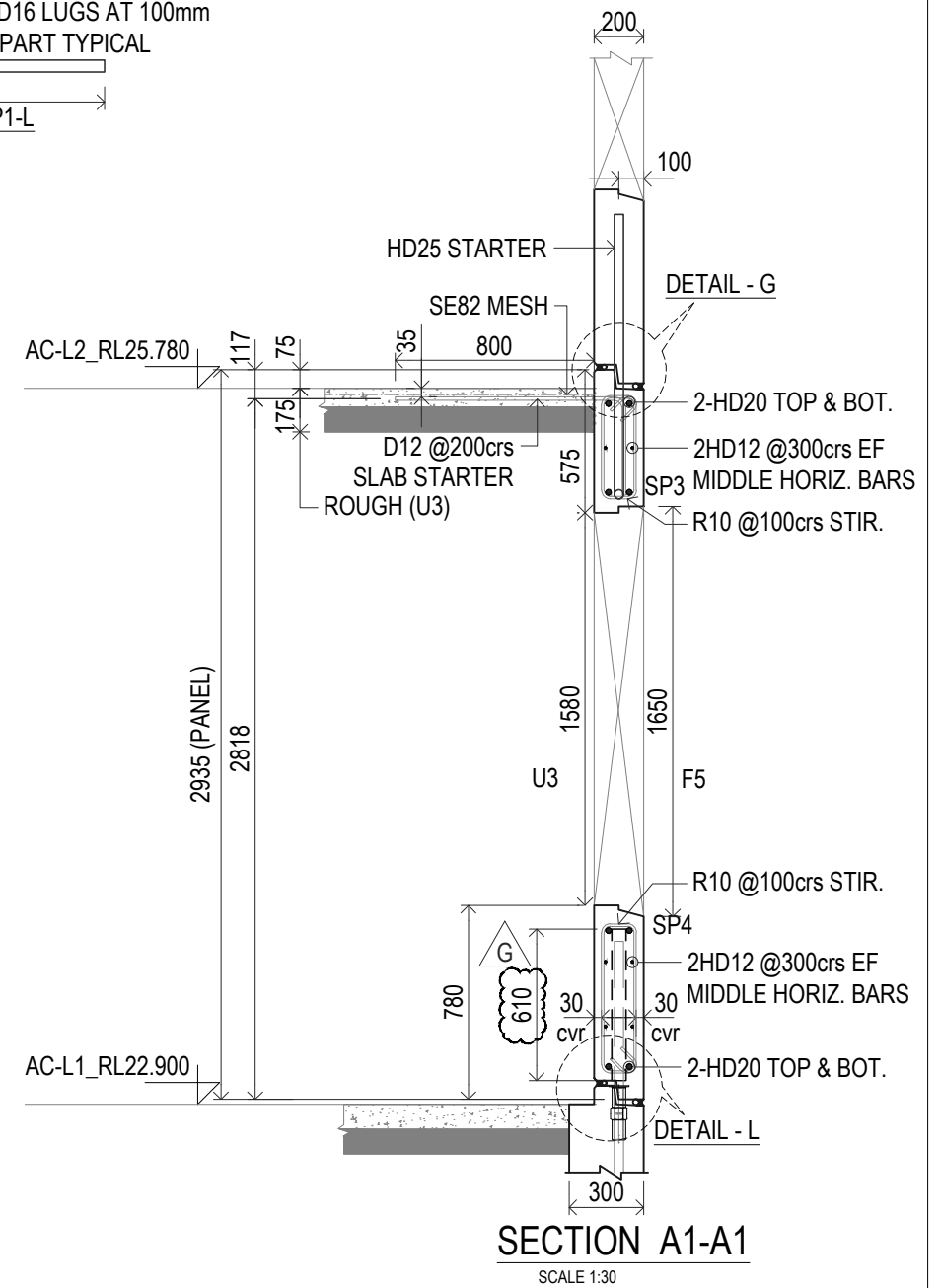
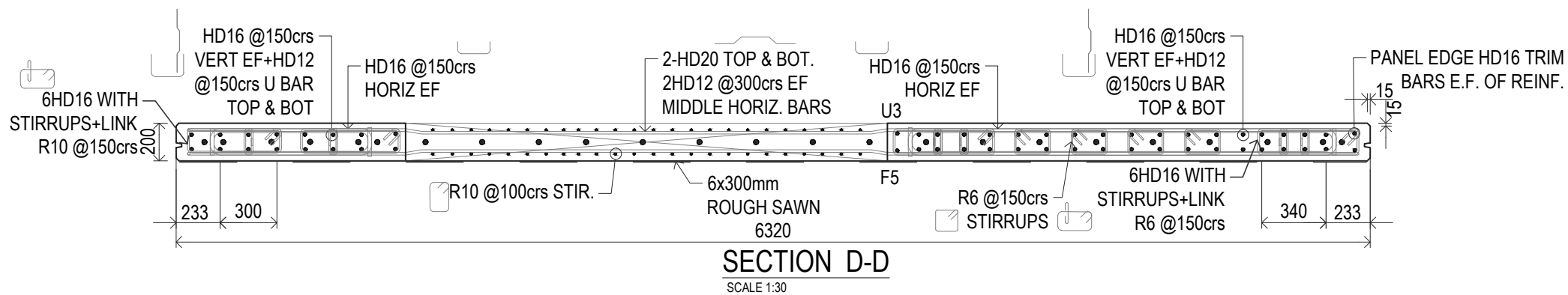
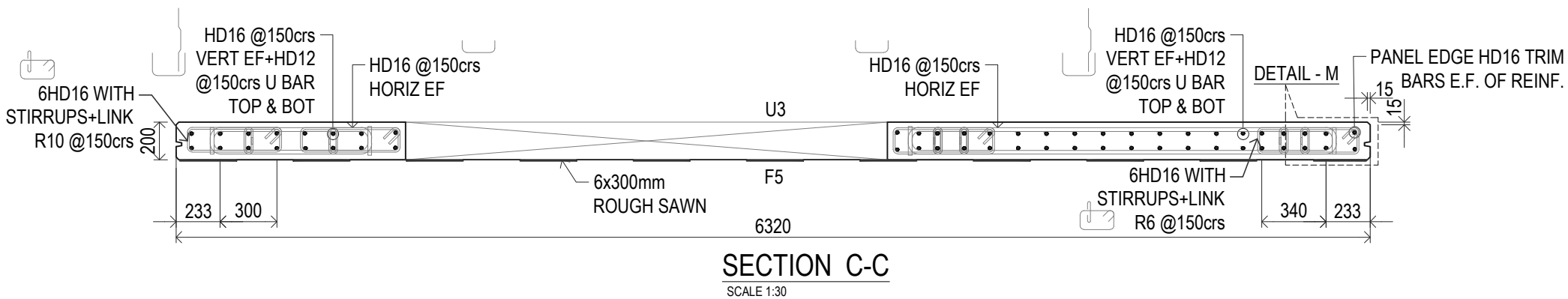
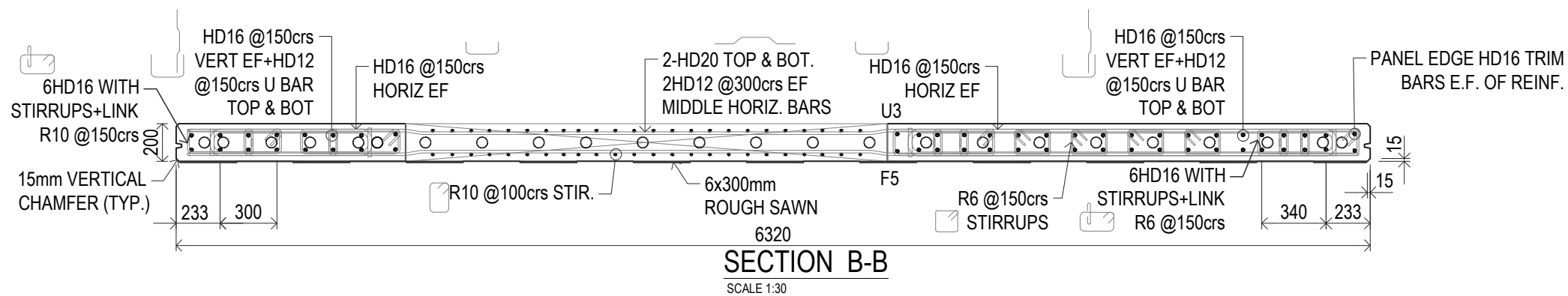

REV.	DATE	DESCRIPTION	DRAWN	APPROVED
G	18.10.22	DROSSBACH HEIGHT REVISED AT WINDOW	JM	
F	02.09.22	REVISED AS PER COMMENTS	JM	
E	27.07.22	REVISED AS PER COMMENTS	AS	
D	25.06.22	REVISED AS PER COMMENTS	AS	
C	18.06.22	REVISED AS PER COMMENTS	AS	

SHEET 2 OF 2

T.B.C. = TO BE CONFIRM

Contractor

Job
MCLEOD GREEN,
148-162 MCLEOD ROAD, TE ATATU SOUTH

Title
785-C-P21
BUILDING C

COPYRIGHT RESERVED	Drawn	AS	Date	2022	Job No.	785
	Checked	PS	Scale (A3)	1:50/1:30	Dwg No.	C-P121/02

G REV.

INSPECTION & TEST PLAN		
INSPECTED BY		
NAME OF FABRICATOR		
UNIT NO.		
CAST DATE		
CAST TIME		
CONCRETE DOCKET NO.		
CONCRETE SPECIF. (MPa)		
ITEM	FABRICATOR INITIAL	APPROVED Y / N
MOULD CLEANLINESS		
RELEASE OIL		
DIMENSIONS		
FORMWORK FIXED		
OPENING / REBATES CORRECT & POSITION		
HOLD POINT		
REINFORCING CORRECT		
LAPS & SPLICES CORRECT		
SPACING & COVER CORRECT		
HOLD POINT		
LIFTERS POSITIONED CORRECTLY		
CAST - IN ITEMS		
STARTERS, LACING BARS		
APPROVED FOR CASTING		

POST POUR INSPECTION		
INSPECTED BY		
DATE		
ITEM		APPROVED Y / N
SWIFTLIFTS POSITION		
SWIFTLIFTS RECESS CLEANED		
CAST-IN ITEMS CLEANED		
CONCRETE FINISH		
LABELLED (NUMBER / DATED)		
DAMAGE (CRACKS / CHIPPING)		
CLEANLINESS		
ANY ACTION REQUIRED:		

APPROVED FOR DISPATCH

SLING ANGLE TO BE NOT LESS THAN 60° TO HORIZONTAL WHEN LIFTING

30 cvr TO ALL EDGES AND FACES (UNO) 30MPa Concrete

CAST IN SUNDRY

60Ø DROSSBACH 1500LG = 16
 7HPAWF(LIFTING HOOK) = 2
 WP1e-L = 4
 WP3-R = 2

AREA (m²)	12.0930
VOLUME (m³)	2.42
WEIGHT (t)	6.29
THICKNESS (mm)	200
CONC. GRADE	30MPa
FINISH MF/NF	F5/U3
NO: OFF	1

REV.	DATE	DESCRIPTION	DRAWN	APPROVED
F	23.11.22	REVISED AS PER COMMENTS	SN	
E	27.07.22	REVISED AS PER COMMENTS	AS	
D	25.06.22	REVISED AS PER COMMENTS	AS	
C	18.06.22	REVISED AS PER COMMENTS	AS	
B	04.06.22	REVISED AS PER COMMENTS	AS	

SHEET 1 OF 2

T.B.C. = TO BE CONFIRM

Drawn	AS	Date	2022	Job No.	785
Checked	PS	Scale (A3)	1:50/1:30	Dwg No.	C-P122/01 F REV.

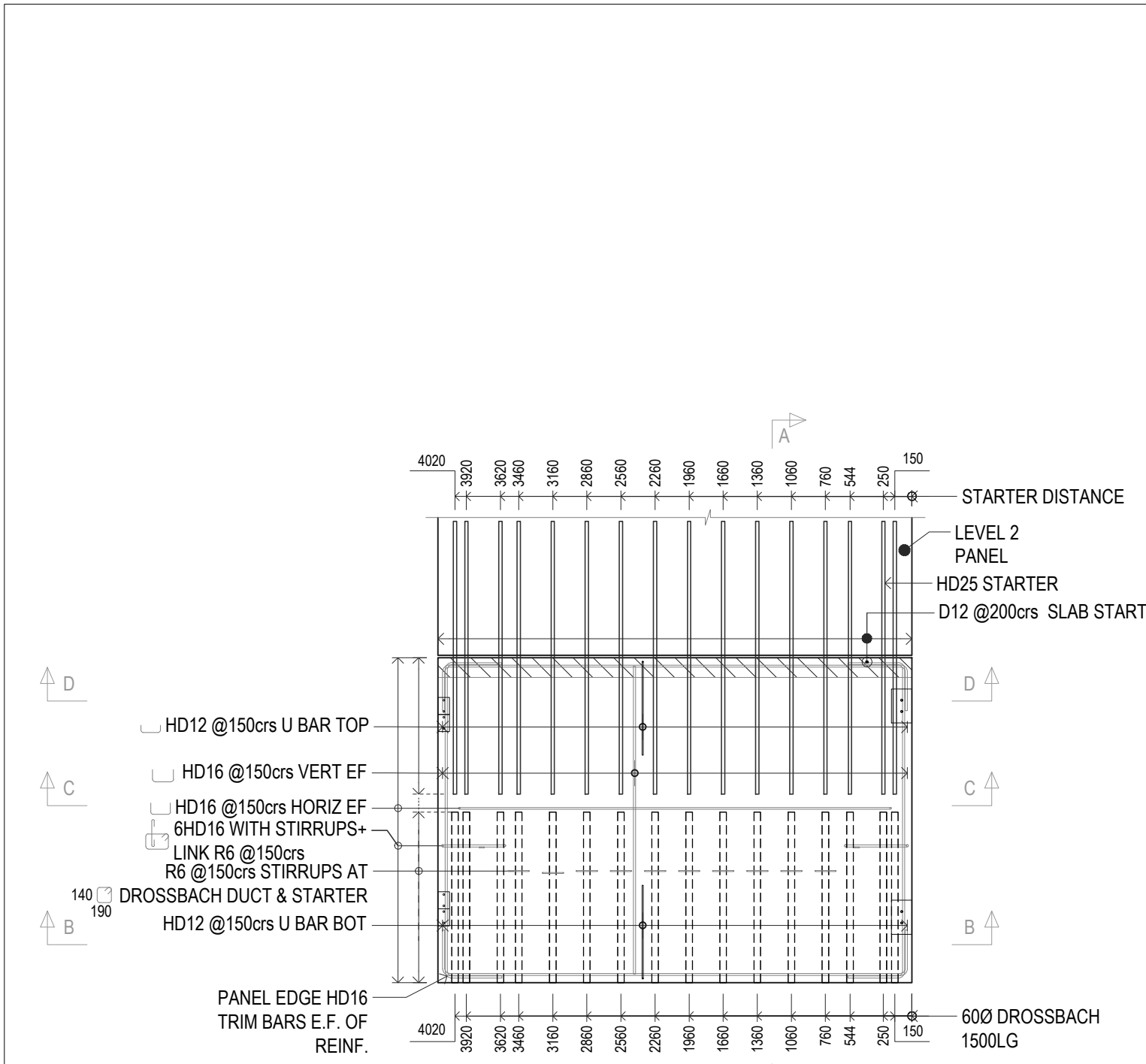

REO LAYOUT
SCALE 1:50
VIEW FROM INSIDE

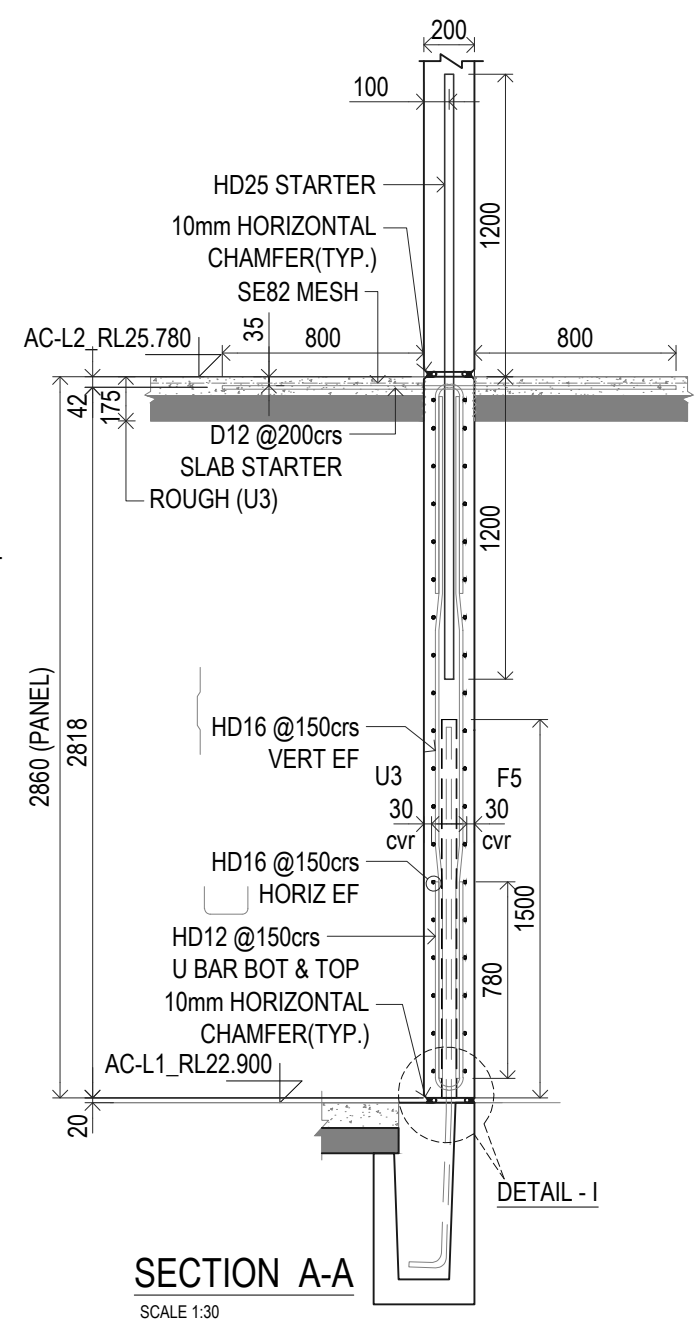

SECTION A-A
SCALE 1:30

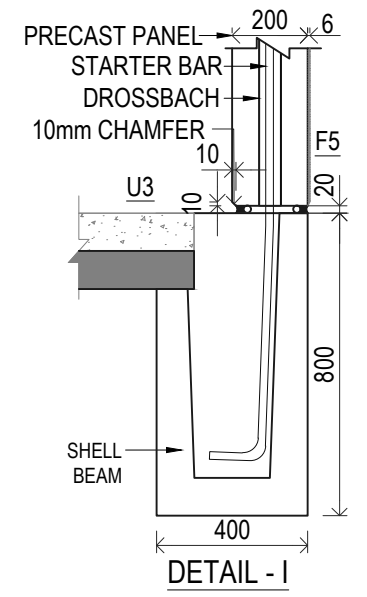

DETAIL - I

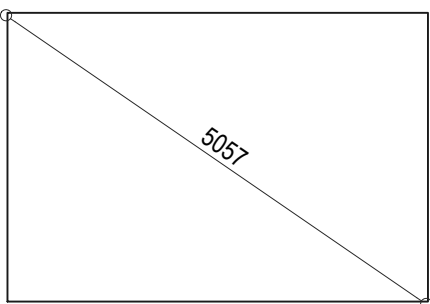

Contractor

Job **MCLEOD GREEN,**
148-162 MCLEOD ROAD, TE ATATU SOUTH

Title **785-C-P22 BUILDING C**

COPYRIGHT RESERVED

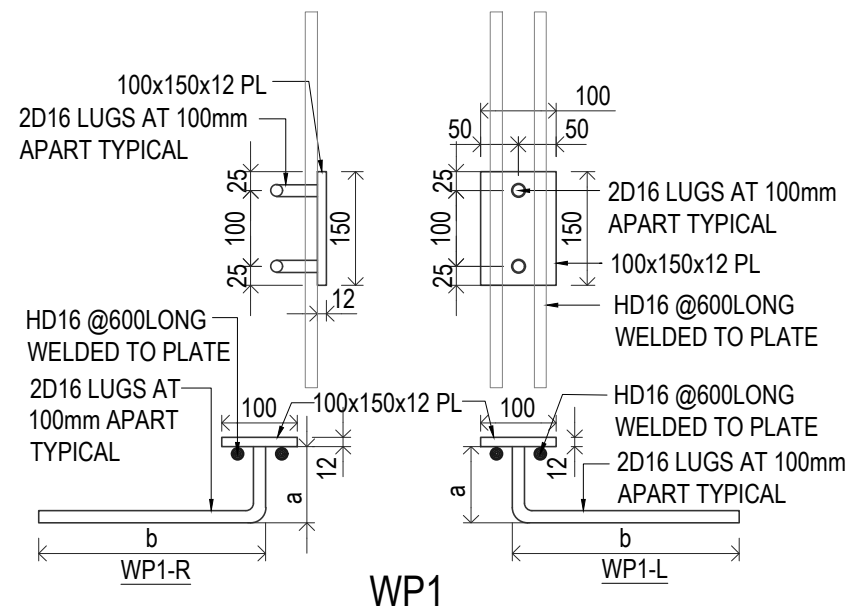
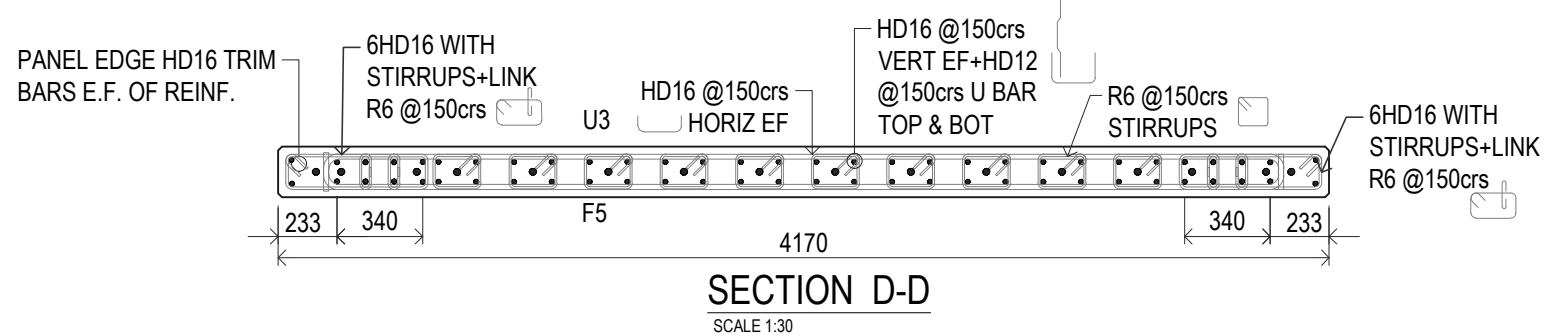
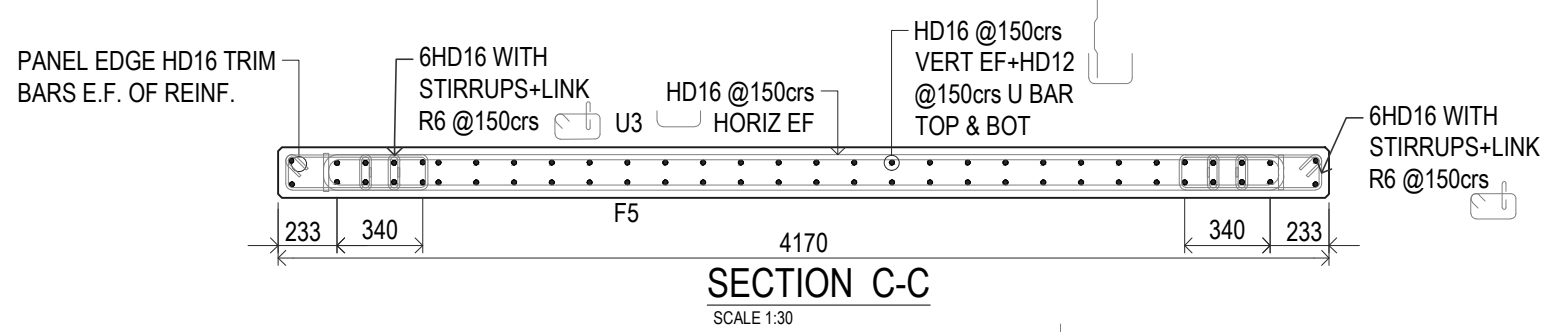
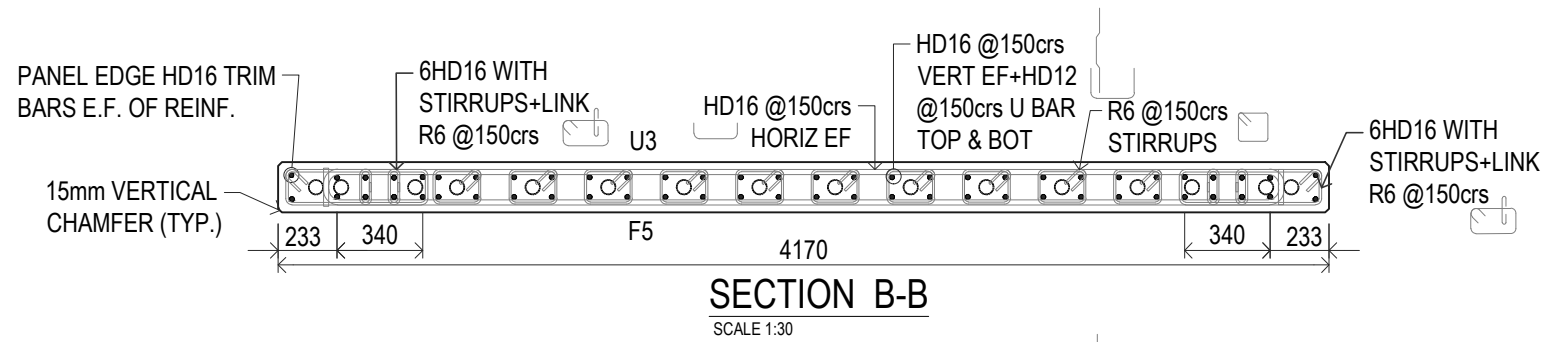
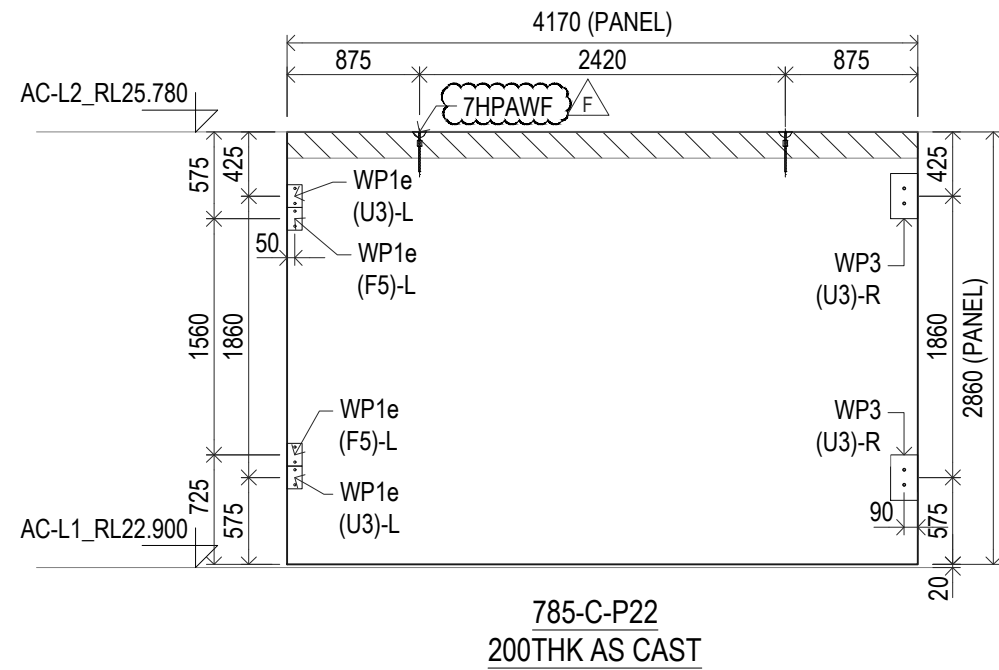

100X12 CAST-IN PLATE
150MM LONG

WELDED PLATE (WP)	a	b
WP1	150	300
WP1a	150	230
WP1b	150	215
WP1c	150	145
WP1d	175	300
WP1e	135	300

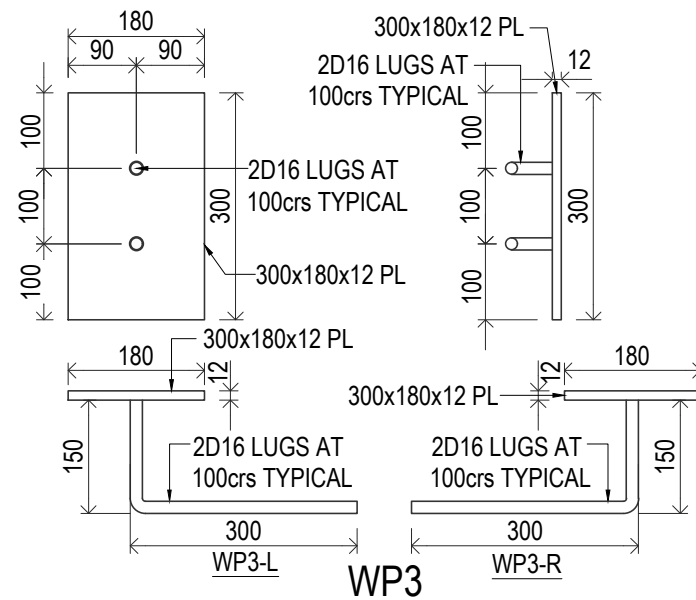

REV.	DATE	DESCRIPTION	DRAWN	APPROVED
F	23.11.22	REVISED AS PER COMMENTS	SN	
E	27.07.22	REVISED AS PER COMMENTS	AS	
D	25.06.22	REVISED AS PER COMMENTS	AS	
C	18.06.22	REVISED AS PER COMMENTS	AS	
B	04.06.22	REVISED AS PER COMMENTS	AS	

SHEET 2 OF 2

T.B.C. = TO BE CONFIRM

Contractor

Job **MCLEOD GREEN,**
148-162 MCLEOD ROAD, TE ATATU SOUTH

Title **785-C-P22**
BUILDING C

COPYRIGHT RESERVED	Drawn	AS	Date	2022	Job No. 785
	Checked	PS	Scale (A3)	1:50/1:30	C-P122/02 F REV.

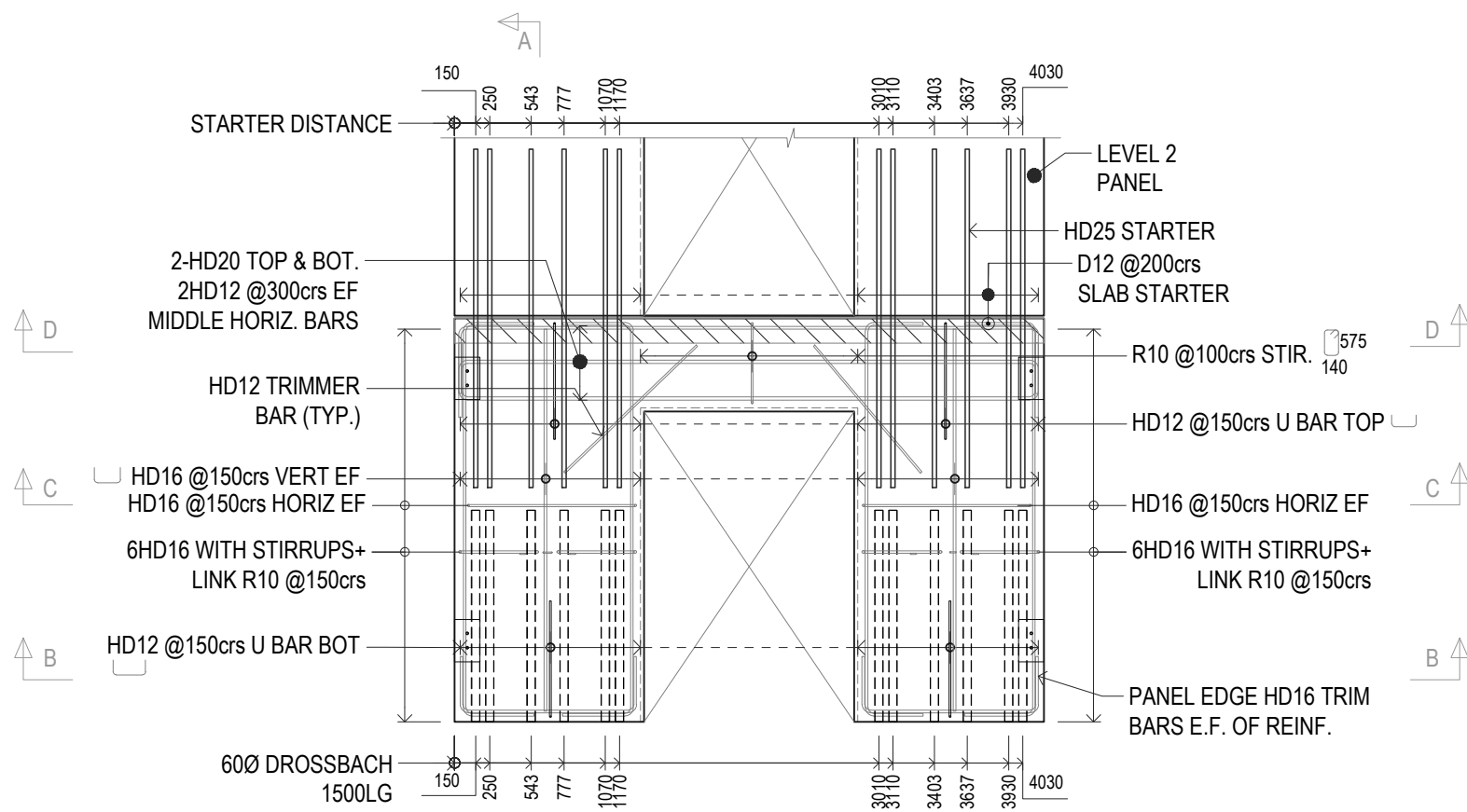

REO LAYOUT
SCALE 1:50
VIEW FROM INSIDE

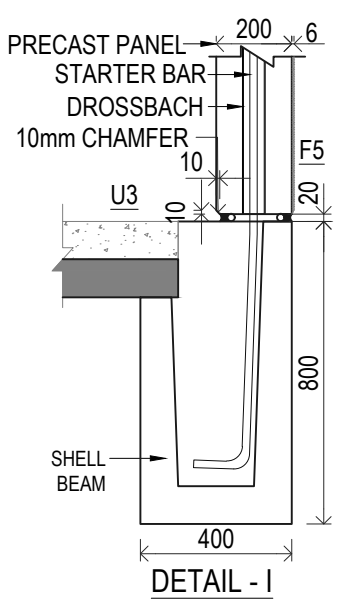

DETAIL - I

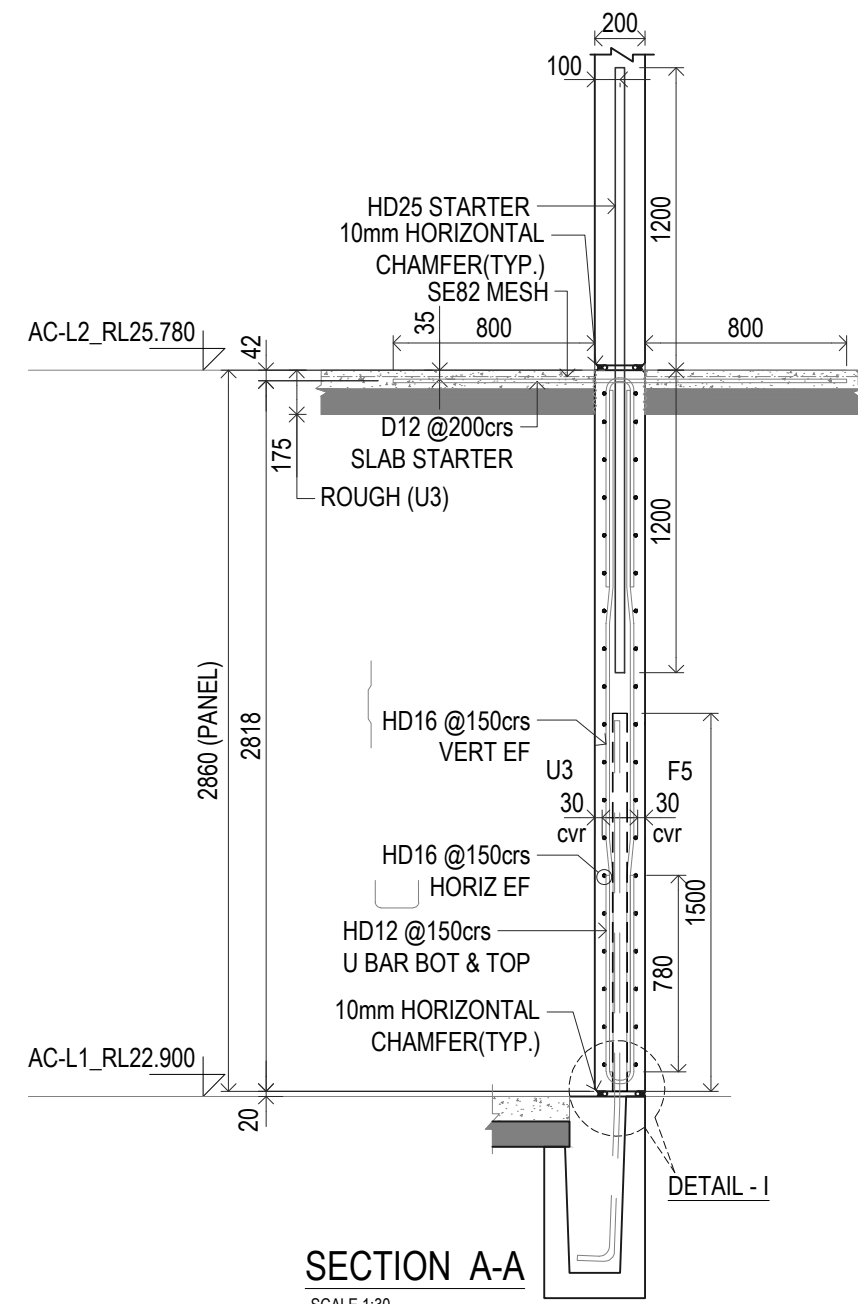
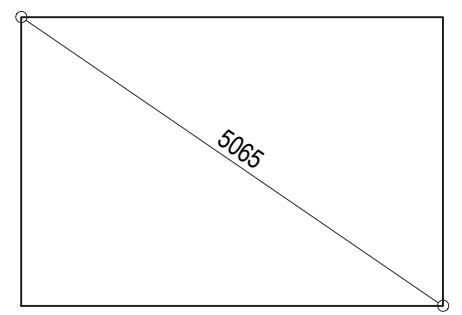

SECTION A-A
SCALE 1:30

DETAIL - I

INSPECTION & TEST PLAN		
INSPECTED BY		
NAME OF FABRICATOR		
UNIT NO.		
CAST DATE		
CAST TIME		
CONCRETE DOCKET NO.		
CONCRETE SPECIF. (MPa)		

ITEM	FABRICATOR INITIAL	APPROVED Y / N
MOULD CLEANLINESS		
RELEASE OIL		
DIMENSIONS		
FORMWORK FIXED		
OPENING / REBATES CORRECT & POSITION		
HOLD POINT		
REINFORCING CORRECT		
LAPS & SPLICES CORRECT		
SPACING & COVER CORRECT		
HOLD POINT		
LIFTERS POSITIONED CORRECTLY		
CAST - IN ITEMS		
STARTERS, LACING BARS		
APPROVED FOR CASTING		

POST POUR INSPECTION		
INSPECTED BY		
DATE		
ITEM		APPROVED Y / N
SWIFTLIFTS POSITION		
SWIFTLIFTS RECESS CLEANED		
CAST-IN ITEMS CLEANED		
CONCRETE FINISH		
LABELLED (NUMBER / DATED)		
DAMAGE (CRACKS / CHIPPING)		
CLEANLINESS		

ANY ACTION REQUIRED:

APPROVED FOR DISPATCH

SLING ANGLE TO BE NOT LESS THAN 60° TO HORIZONTAL WHEN LIFTING

30 cvr TO ALL EDGES AND FACES (UNO) 30Mpa Concrete

CAST IN SUNDRY

60φ DROSSBACH 1500LG = 12
 7HPAWF(LIFTING HOOK) = 2
 WP3-L = 2
 WP3-R = 2

AREA (m²)	8.6056
VOLUME (m³)	1.72
WEIGHT (t)	4.47
THICKNESS (mm)	200
CONC. GRADE	30MPa
FINISH MF/NF	F5/U3
NO: OFF	1

REV.	DATE	DESCRIPTION	DRAWN	APPROVED
G	23.11.22	REVISED AS PER COMMENTS	SN	
F	02.09.22	REVISED AS PER COMMENTS	JM	
E	27.07.22	REVISED AS PER COMMENTS	AS	
D	25.06.22	REVISED AS PER COMMENTS	AS	
C	18.06.22	REVISED AS PER COMMENTS	AS	

SHEET 1 OF 2

T.B.C. = TO BE CONFIRM

Contractor	Job	Title	Drawn	AS	Date	2022	Job No.	785
	MCLEOD GREEN, 148-162 MCLEOD ROAD, TE ATATU SOUTH	785-C-P22a BUILDING C	Checked	PS	Scale (A3)	1:50/1:30	C-P122a/01	G
							Dwg No.	REV.

COPYRIGHT RESERVED

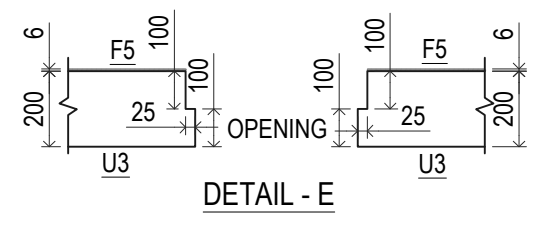
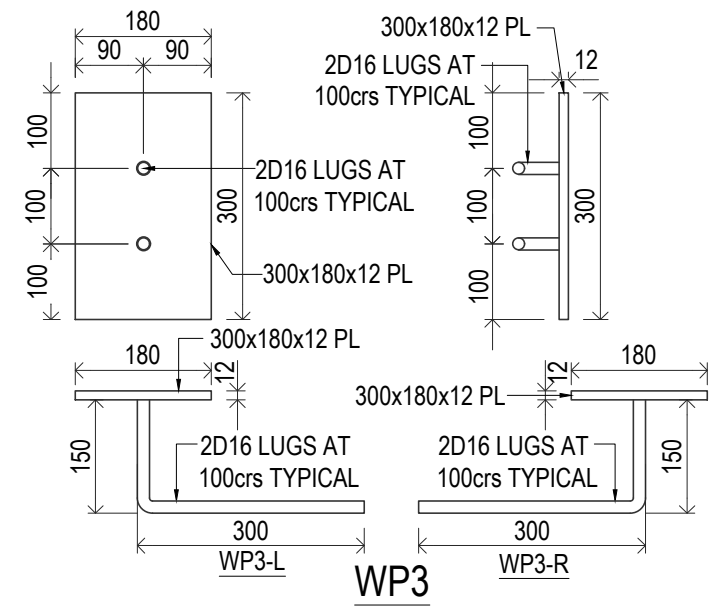
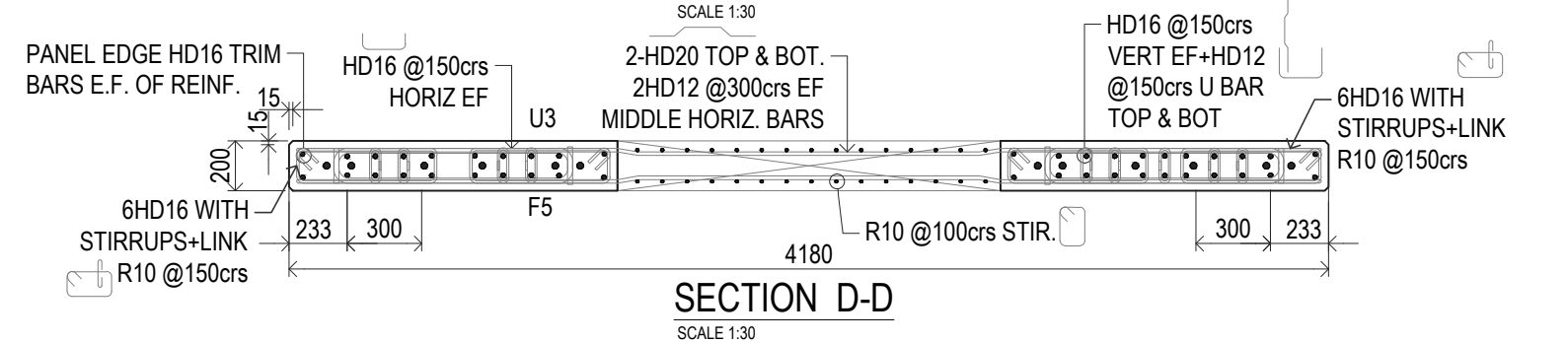
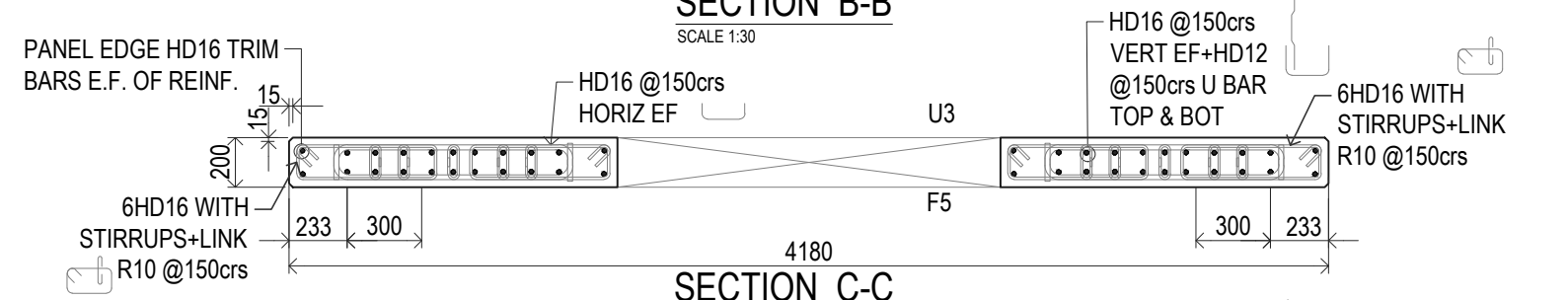
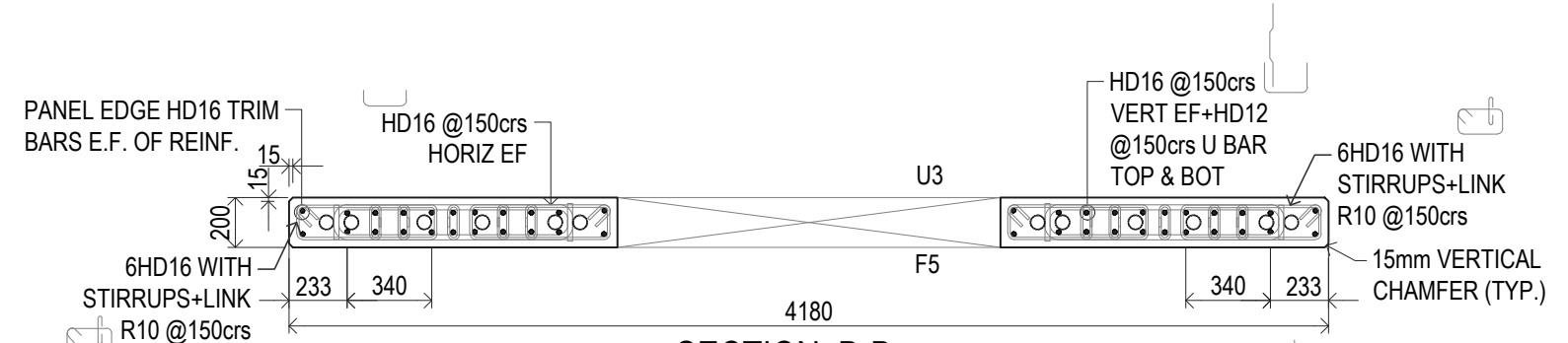
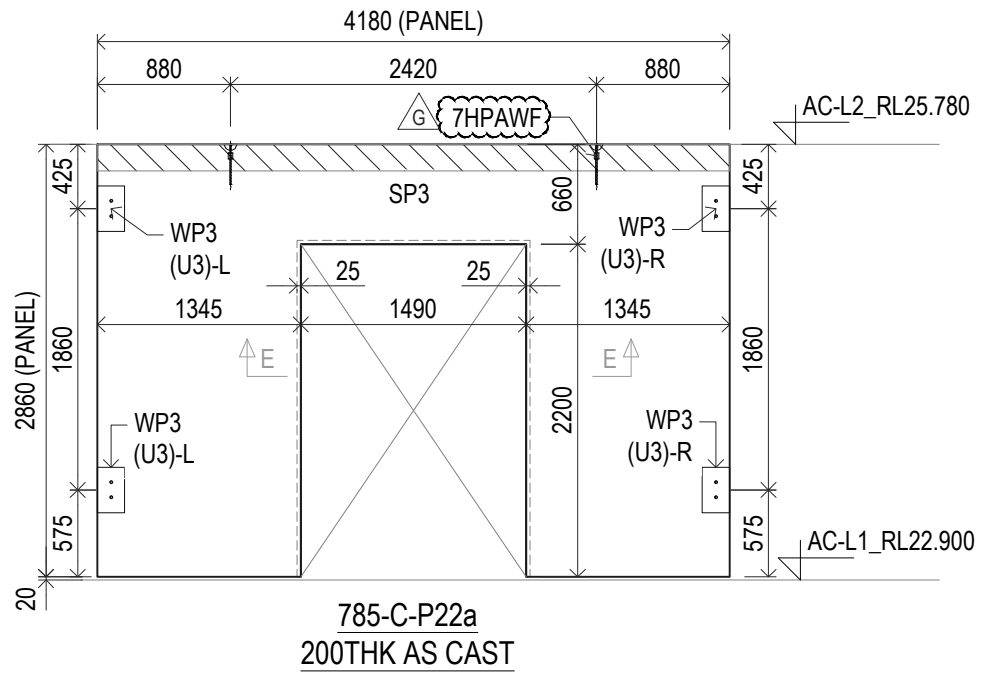

SHEET 2 OF 2

T.B.C. = TO BE CONFIRM

REV.	DATE	DESCRIPTION	DRAWN	APPROVED
G	23.11.22	REVISED AS PER COMMENTS	SN	
F	02.09.22	REVISED AS PER COMMENTS	JM	
E	27.07.22	REVISED AS PER COMMENTS	AS	
D	25.06.22	REVISED AS PER COMMENTS	AS	
C	18.06.22	REVISED AS PER COMMENTS	AS	

COPYRIGHT RESERVED	Contractor	Job	MCLEOD GREEN, 148-162 MCLEOD ROAD, TE ATATU SOUTH		Title	785-C-P22a BUILDING C		Drawn	AS	Date	2022	Job No.	785
	Checked	PS	Scale (A3)	1:50/1:30	C-P122a/02	G	REV.						

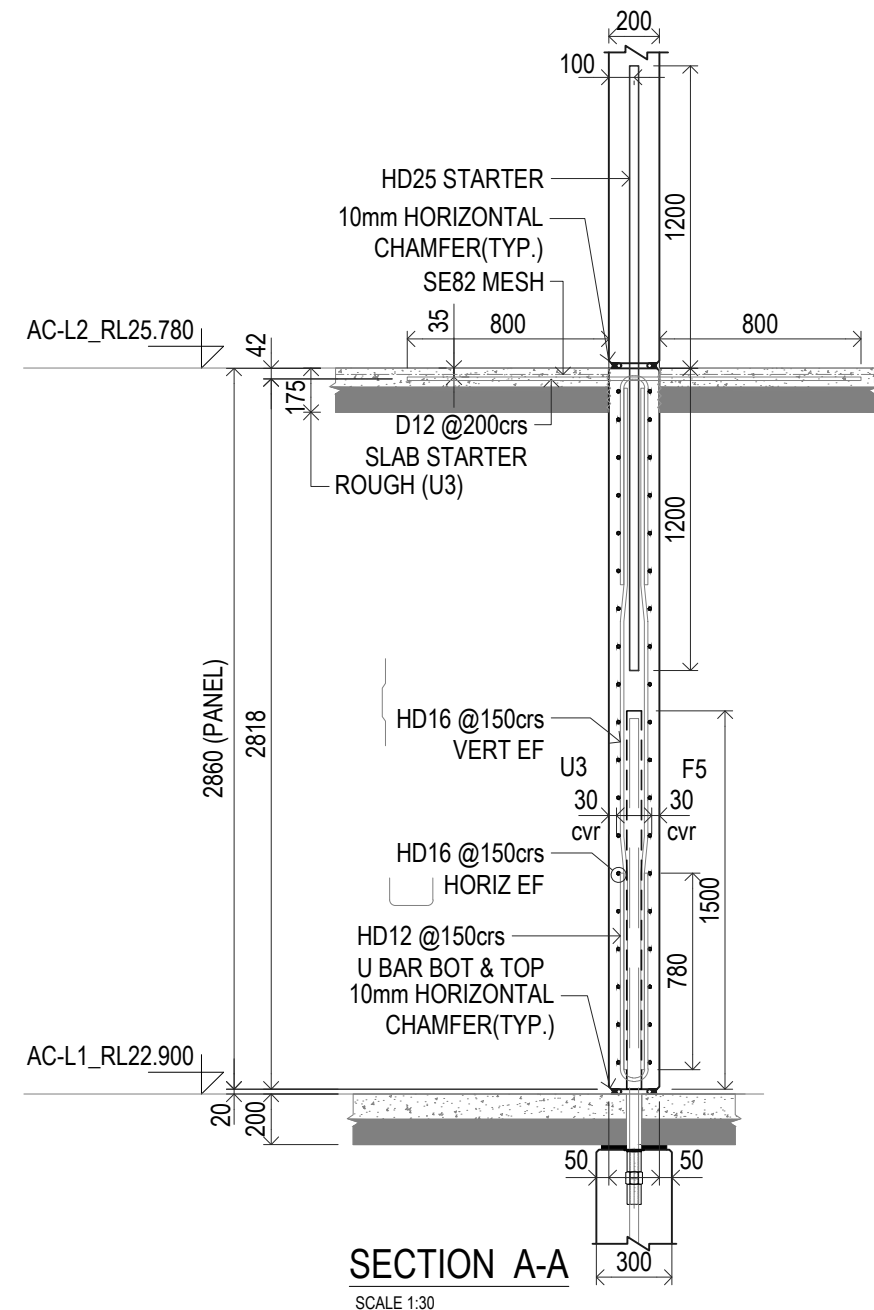
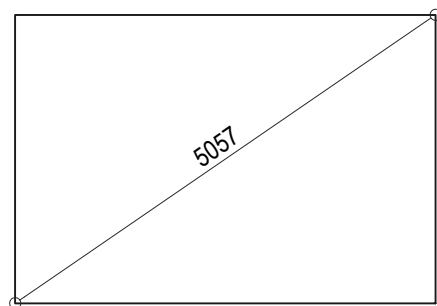
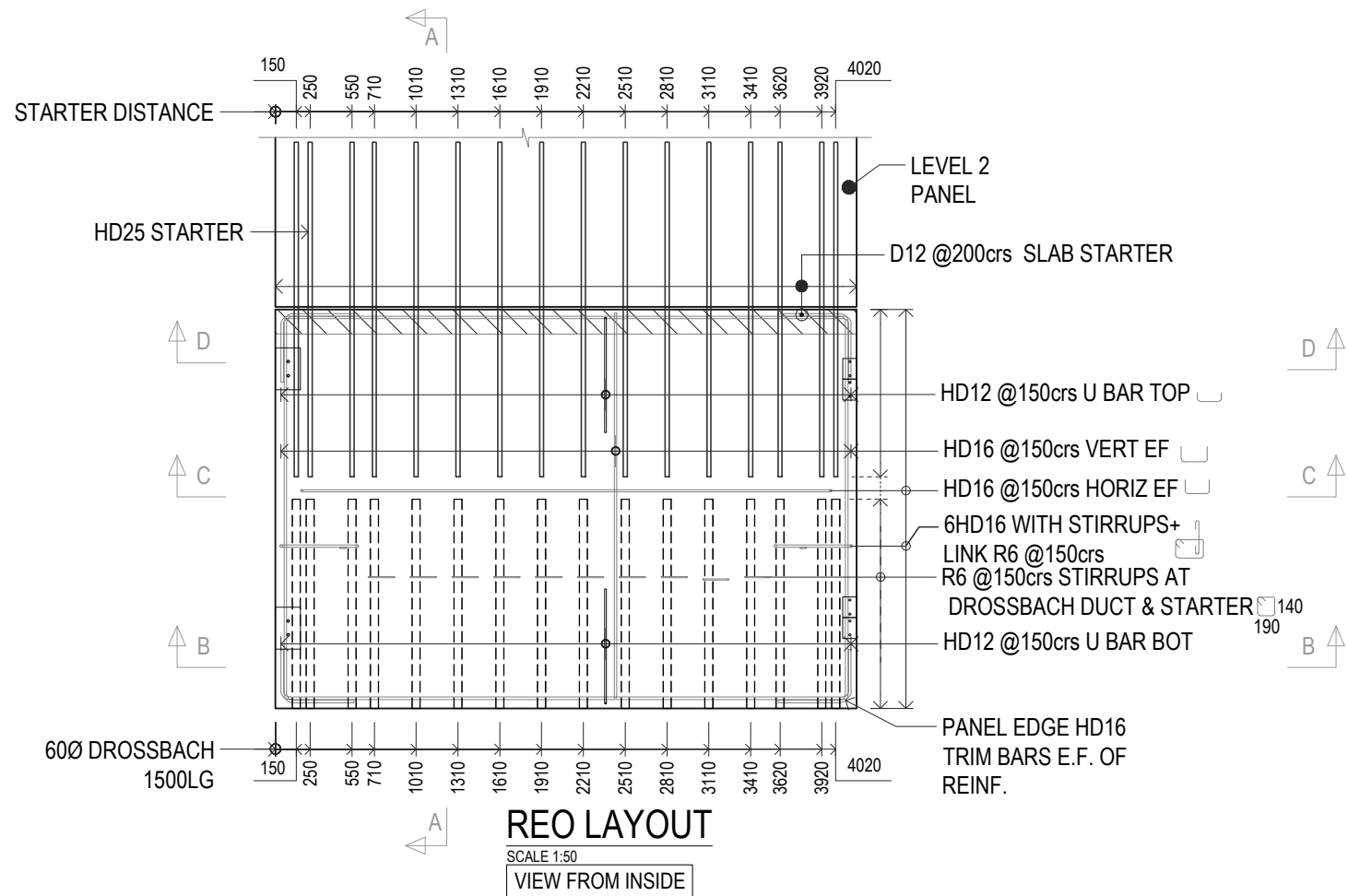

INSPECTION & TEST PLAN	
INSPECTED BY	
NAME OF FABRICATOR	
UNIT NO.	
CAST DATE	
CAST TIME	
CONCRETE DOCKET NO.	
CONCRETE SPECIF. (MPa)	

ITEM	FABRICATOR INITIAL	APPROVED Y / N
MOULD CLEANLINESS		
RELEASE OIL		
DIMENSIONS		
FORMWORK FIXED		
OPENING / REBATES CORRECT & POSITION		
HOLD POINT		
REINFORCING CORRECT		
LAPS & SPLICES CORRECT		
SPACING & COVER CORRECT		
HOLD POINT		
LIFTERS POSITIONED CORRECTLY		
CAST - IN ITEMS		
STARTERS, LACING BARS		
APPROVED FOR CASTING		

POST POUR INSPECTION	
INSPECTED BY	
DATE	
ITEM	APPROVED Y / N
SWIFTLIFTS POSITION	
SWIFTLIFTS RECESS CLEANED	
CAST-IN ITEMS CLEANED	
CONCRETE FINISH	
LABELLED (NUMBER / DATED)	
DAMAGE (CRACKS / CHIPPING) CLEANLINESS	
ANY ACTION REQUIRED:	

APPROVED FOR DISPATCH
SLING ANGLE TO BE NOT LESS THAN 60° TO HORIZONTAL WHEN LIFTING
30 cvr TO ALL EDGES AND FACES (UNO) 30Mpa Concrete

CAST IN SUNDRY	
60φ DROSSBACH 1500LG = 16	
7HPAWF(LIFTING HOOK) = 2	
WP3-L = 2	
WP1e-R = 4	

AREA (m²)	12.0930
VOLUME (m³)	2.42
WEIGHT (t)	6.29
THICKNESS (mm)	200
CONC. GRADE	30MPa
FINISH MF/NF	F5/U3
NO: OFF	1

REV.	DATE	DESCRIPTION	DRAWN	APPROVED
F	23.11.22	REVISED AS PER COMMENTS	SN	
E	27.07.22	REVISED AS PER COMMENTS	AS	
D	25.06.22	REVISED AS PER COMMENTS	AS	
C	18.06.22	REVISED AS PER COMMENTS	AS	
B	04.06.22	REVISED AS PER COMMENTS	AS	

SHEET 1 OF 2

T.B.C. = TO BE CONFIRM

Contractor	Job	Title	COPYRIGHT RESERVED	Drawn	AS	Date	2022	Job No.	785
	MCLEOD GREEN, 148-162 MCLEOD ROAD, TE ATATU SOUTH	785-C-P22b BUILDING C		Checked	PS	Scale (A3)	1:50/1:30	C-P122b/01	F

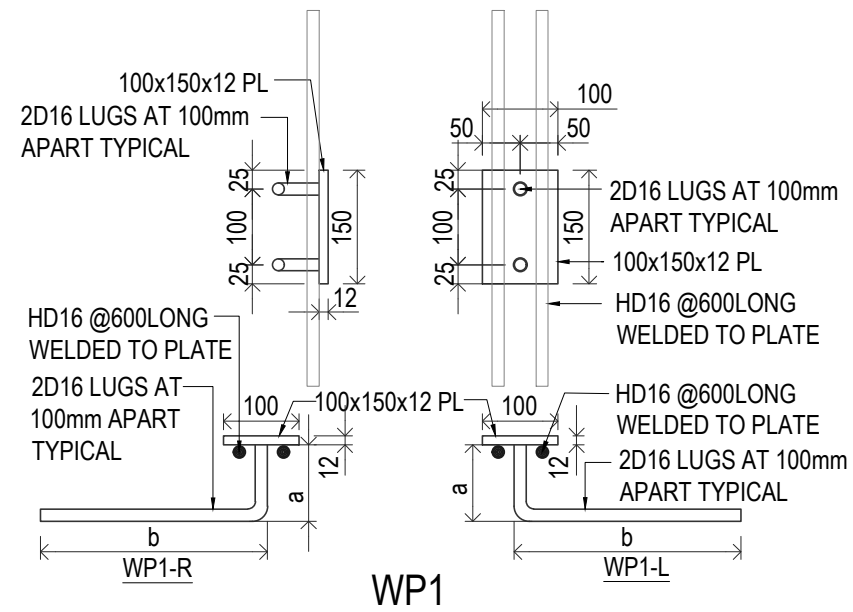
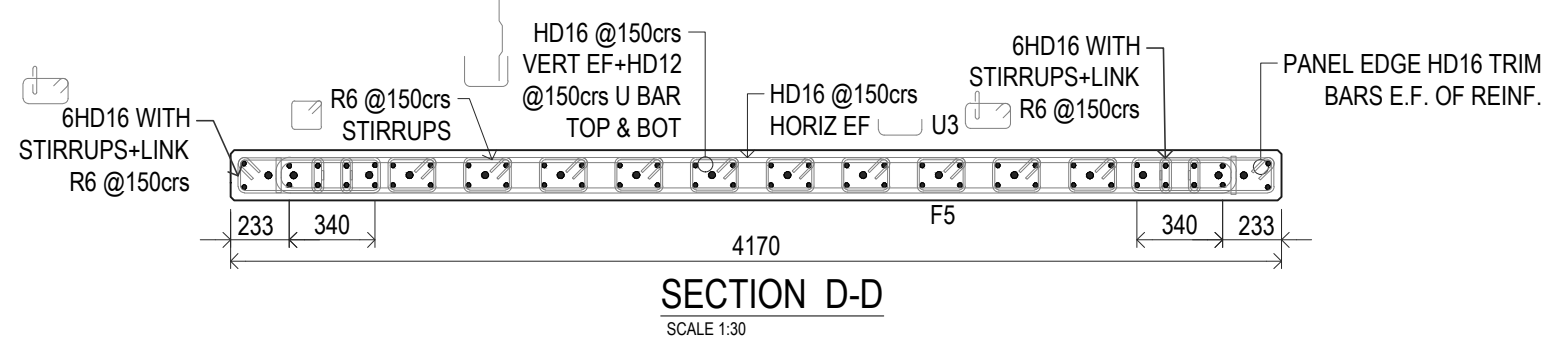
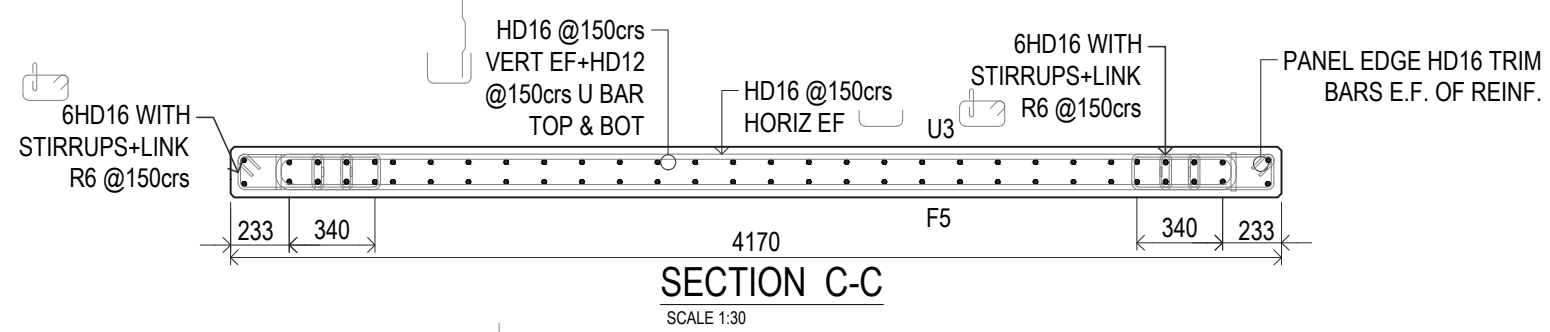
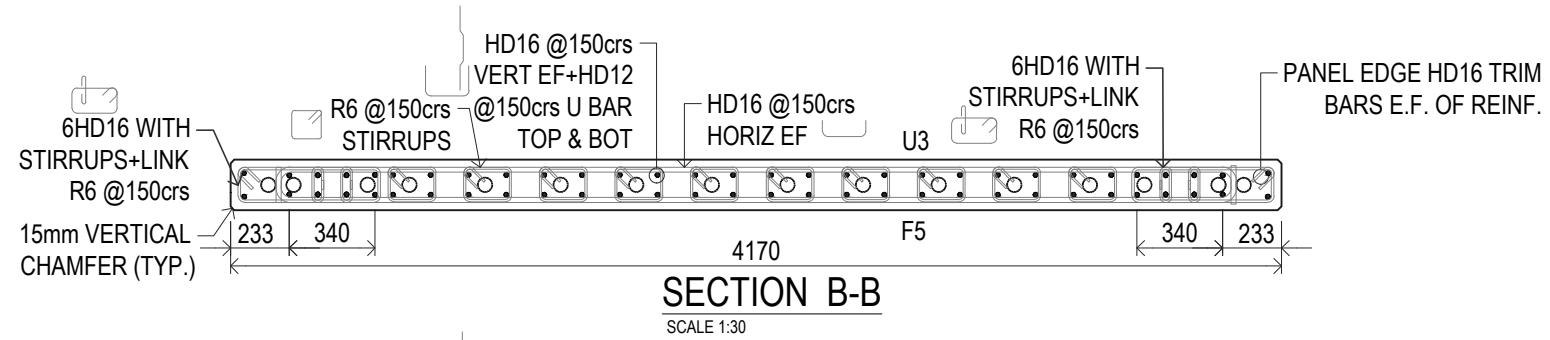
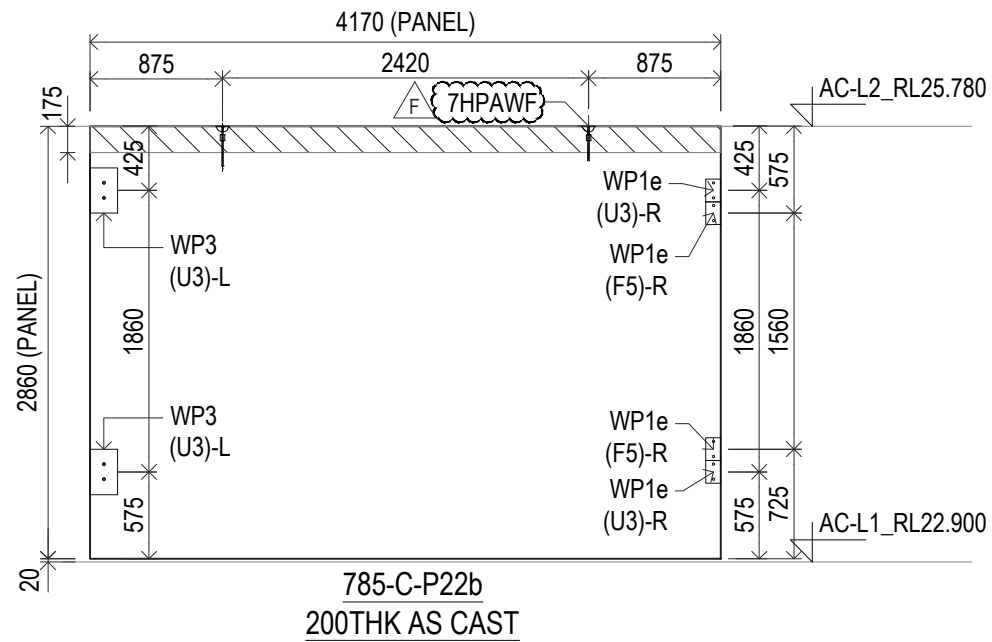

100X12 CAST-IN PLATE
150MM LONG

WELDED PLATE (WP)	a	b
WP1	150	300
WP1a	150	230
WP1b	150	215
WP1c	150	145
WP1d	175	300
WP1e	135	300

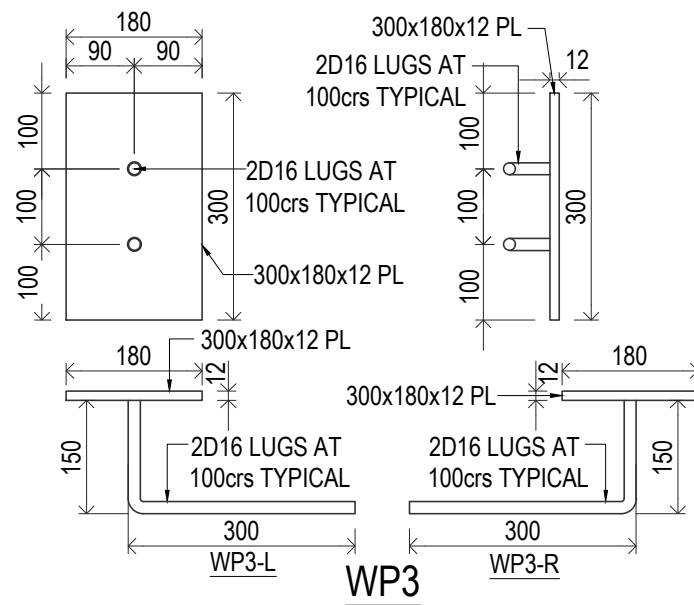

REV.	DATE	DESCRIPTION	DRAWN	APPROVED
F	23.11.22	REVISED AS PER COMMENTS	SN	
E	27.07.22	REVISED AS PER COMMENTS	AS	
D	25.06.22	REVISED AS PER COMMENTS	AS	
C	18.06.22	REVISED AS PER COMMENTS	AS	
B	04.06.22	REVISED AS PER COMMENTS	AS	

SHEET 2 OF 2

T.B.C. = TO BE CONFIRM

Contractor

Job
MCLEOD GREEN,
148-162 MCLEOD ROAD, TE ATATU SOUTH

Title
785-C-P22b
BUILDING C

COPYRIGHT
RESERVED

Drawn	AS	Date	2022	Job No.	785
Checked	PS	Scale (A3)	1:50/1:30	C-P122b/02	F